

Firmware Tde Macno

User's manual  
FEIMM application n°71



Cod. MW01201E00 V\_1.1





---

## INDEX

1. INTRODUCTION .....	2
1.1 ABOUT THIS MANUAL .....	2
1.2 COMMON SYMBOLS AND ABBREVIATIONS .....	2
1.3 INTENDED AUDIENCE .....	2
1.4 UNIT MEASURING SYSTEM .....	2
2. OpdeFEIMM PROFILES.....	3
2.1 OpdeFEIMM PROFILES SUPPORTED .....	3
2.2 NEW FIRMWARE FUNCTIONS .....	3
2.3 DEVICE CONTROL.....	3
2.3.1 CONTROL WORD AND STATUS WORD .....	6
2.3.2 STATE MACHINE .....	8
2.3.3 EXTRA VIEW .....	9
2.3.4 CAN2 AND SPI .....	10
2.4 PROFILE VELOCITY MODE .....	12
2.5 HOMING MODE .....	14
2.6 MULTI PROFILE POSITION MODE .....	16
2.6.1 PROFILE POSITIVE .....	20
2.6.2 PROFILE NEGATIVE .....	28
2.6.3 HOLDING TORQUE PROFILE .....	35
2.7 MULTI-PROFILE VELOCITY MODE .....	50
2.7.1 VELOCITY PROFILE POSITIVE.....	52
2.7.2 VELOCITY PROFILE NEGATIVE .....	58
2.8 PROFILE VELOCITY PI CONTROL MODE .....	63
2.9 PWM SYNCHRONIZATION.....	69
2.10 ALARMS.....	71
2.11 DIGITAL INPUT AND OUTPUT .....	71
3. APPLICATION REVISION HISTORY .....	73

---

# VERSION APPLICATION: 71.00

## 1. INTRODUCTION

### 1.1 ABOUT THIS MANUAL

This manual is meant as a brief explanation of OPDE CAN OPEN DSP402. The manual contains the following chapters:

- **Revision Table** contains the history revision of the manual;
- **Introduction** provides information background about the manual;
- **CAN OPEN DSP402 Profiles** contains the DSP402 Profiles cabling instruction and general information about EtherCAT connections;

### 1.2 COMMON SYMBOLS AND ABBREVIATIONS

Abbreviations	Explanations
CAN	Controller Area Network
CiA	CAN in Automation
EMCY	Emergency Object or Service
OPDE	Open Drive Exp or OPDExp
OPD Explorer	OPD Explorer Supervisory Software
SDO	Service Data Object

### 1.3 INTENDED AUDIENCE

The manual is intended for those persons who are responsible for commissioning and using an OPDE CAN Module. The reader should have some basic knowledge of networking, electrical fundamentals, electrical wiring practices and how to work the OPDE drive and OPD Explorer.

### 1.4 UNIT MEASURING SYSTEM

The units of measurement used by CAN Open DSP 402 are the following:

- Positions are expressed in "ie" (encoder pulse). One mechanical motor revolution is 65536 ie (or encoder pulses, default);
- Speed are expressed in "ie/s". One revolutions-per-second is 65536 ie/s (default);
- Accelerations are expressed in "ie/s<sup>2</sup>". One revolutions-per-second<sup>2</sup> is 65536 ie/s<sup>2</sup> (default)

---

## 2. OpdeFEIMM PROFILES

### 2.1 OpdeFEIMM PROFILES SUPPORTED

In OPDE drive are implemented the following CAN profiles:

- **Device Control;**
- **Profile Velocity Mode;**
- **Profile Position Mode;**
- **Multi-Profile Position Mode;**
- **Homing Mode;**
- **Profile velocity PI control Mode;**
- 

### 2.2 NEW FIRMWARE FUNCTIONS

For ENDAT and ENDAT/BISS is possible to set feed-back baud-rate with **C65 – ENDAT\_BISS\_BAUD\_SEL**.

Default value is 36 – 1 Mbit/s.

If the cable length is not very high, is possible to increase the baud-rate.

### 2.3 DEVICE CONTROL

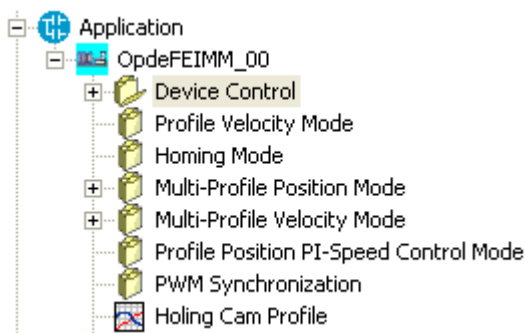

Device controls is a profile that define the behaviour of the control device. The master controls like the slave works with the following objects:

- Control Word;
- Status word;
- Modes of operation;
- Modes of operation display;
- Quick stop option code;
- Quick stop deceleration;

Parameter **E96-pCYCLICPERIOD** allows to set the synchronization for cyclic task.

User can chose the resolution of the sensor with parameter **E97-pPOS\_FRAC**. The default value is 16 which means 1 mechanical turn = 65536 ( $2^{16}$ ) i.e.

If the value is different, the value of 1 mechanical turn is  $2^{pPOS\_FRAC}$  i.e.

Example: E97-pPOS\_FRAC = 16,

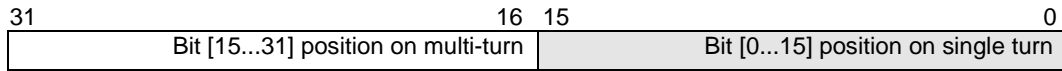

One mechanical turn is  $2^{16} = 65536$  ie,

E97-pPOS\_FRAC = 19,



One mechanical turn is  $2^{19} = 524288$  ie,

**E99 – INIT\_PAR** is used for the external control initialization.

Parameter **E96 – pCYCLIC\_PERIOD** allows to set the cyclic task duration (default 0.8 – 1.0 ms).

Name	Description	Min	Max	Default	UM	Scale	index	Type	Access
rCONTROL_WORD	E100 – Control Word			0000		1	CAN: 0x6040 MODBUS: 0x2000	UNSIGNED D16	R/W
STATUS_WORD	d64 – Status Word			0000		1	0x6041 0x03C0	UNSIGNED D16	R/W
RD_STATE_MACHINE	E101 – Finite State Machine					1	0x2001		R
pMODE_OF_OP	E01 – Mode of operations	Range		3		1	0x6060	INTEGER8	R/W
		1	1-Profile Position Mode						
		2	2-Multi Profile Position Mode						
		3	3-Profile Velocity Mode						
		4	4-Profile Velocity Mode with PI control						
6	6-Homing mode								
MODE_OF_OP_DIS	d65 – Modes of operation display						0x6061 0x03C1	INTEGER8	R
pQSDEC	E08 – 09 – Quick stop deceleration	10223	2147483647	1638400	ie/s <sup>2</sup>	1	0x3102 sub 0x04 0x0134-0x0135	INTEGER32	R/W
pQSOPTC	E38 – Quick Stop Option Code	Range				1	0x3102 sub 0x13 (16 lsb) 0x0152		R/W
		0							
		2	2 – Switch On Disabled						
		6	6 – Stay in Quick Stop						
8									
ACTUALPOS	d66-67 – Position actual value				ie		0x6064 0x03C2 - 0x03C3	INTEGER32	R
ACTUALVEL	d68-69 – Velocity actual value				ie/s		0x606C	INTEGER32	R

Name	Description	Min	Max	Default	UM	Scale	index	Type	Access
							0x03C4 - 0x03C5		
MAX_SPEED_IE	d72-73 – Speed Max [ie] (P65 – MOT_MAX_SPEED)				ie/s		0x200F sub 0x48 0x03C8 - 0x03C9	INTEGER3 2	R
INIT_PAR	E99 – Init Parameters from master Ok	-1999	1999				0x3102 sub 0x62 (16 msb) 0x018F	INTEGER3 2	R/W
pCYCLICPERIOD	E96 - Cyclic Period Duration	0.2	10.0	1.0	ms	10	0x3102 sub 0x60 (16 lsb) 0x018C	INTEGER3 2	R/W
pPOS_FRAC	E97 - Fractional position	16	25	1.0	Bit		0x3102 sub 0x60 (16 msb) 0x018D	INTEGER3 2	R/W
CAN2_Selection	E899 – Position send/received by CAN2	Range					0x231F	INTEGER1 6	
		0	0 - Use motor position						
		1	1 – Use motor position and send it						
		2	2 - Receive position by CAN 2						
		3	3 - Send Torque and position by SPI (Master)						
		4	4 - Receive Pos by SPI (Slave)						
CAN2_TX_ID	E900 – Transmitter CAN2 Address	0	127				0x2320	INTEGER1 6	R/W
CAN2_RX_ID	E901 – Receiver CAN2 Address	0	127				0x2321	INTEGER1 6	R/W

**Tab. 1- Device Control Parameters and Objects**

### 2.3.1 CONTROL WORD AND STATUS WORD

Control word and status word are used for the device control of the system (See **Fig. 4**). Both of them became from standard CAN Open Dsp402. Some commands of Control Word are in OR state with Logical Inputs.

15	14	13	12	11	10	9	8	7	6	5	4	3	2	1	0
TrqLFLB	bCw_PowRes			PrfNeg	PrfPos		hlt	fr	b6	b5	nsp	eo	qs	ev	so

**Fig. 1-Control Word**

0	Switched On (Ds402)
1	Enable Voltage (Ds402)
2	Quick Stop (Ds402)
3	Enable Operation (Ds402)
4	New Set Point (Ds402)
5	b5 (Ds402)
6	b6 (Ds402)
7	Fault reaction (Ds402)
8	Halt (Ds402)
9	
10	Enable Positive Multi-profile position (rising edge)
11	Enable Negative Multi-profile position (rising edge)
12	
13	
14	Power reset
15	Enable Torque limit from fieldbus

**Tab. 2- Meaning of control word**

15	14	13	12	11	10	9	8	7	6	5	4	3	2	1	0
ms_b1	ms_b0	oms_b1	oms_b0	ila	tr	rm	HmC	w	sod	qs	ve	f	oe	so	rtso

**Fig. 2-Status Word**

0	Ready to Switch On State (Ds402)
1	Switched On State (Ds402)
2	Operation Enable State (Ds402)
3	Fault State (Ds402)
4	Voltage Enabled (Ds402)
5	Quick Stop State (Ds402)
6	Switch On Disabled State (Ds402)
7	Warning (Ds402)
8	Homing Completed (Ds402)
9	Remote (Ds402)
10	Target Reached
11	Internal Limit Active (Ds402)
12	Op. Mode specific 0
13	Op. Mode specific 1



14	Manufacturer specific 0
15	Manufacturer specific 1

**Tab. 3- Meaning of status word**

15	14	13	12	11	10	9	8	7	6	5	4 Can2Rx	3 Can2Tx	2	1 NegLim	0 PosLim
----	----	----	----	----	----	---	---	---	---	---	-------------	-------------	---	-------------	-------------

**Tab. 4- Meaning of status word**

0	Positive limit active
1	Negative limit active

**Fig. 3-Status Word 1**

### 2.3.2 STATE MACHINE

Fig. 4 shows the device control of the machine and bits of control word used like transition between the states. Parameter **E101-RD\_STATE\_MACHINE** refreshes the actual state of the machine. Speed references are processed only when the system is in **Operation Enabled State**.

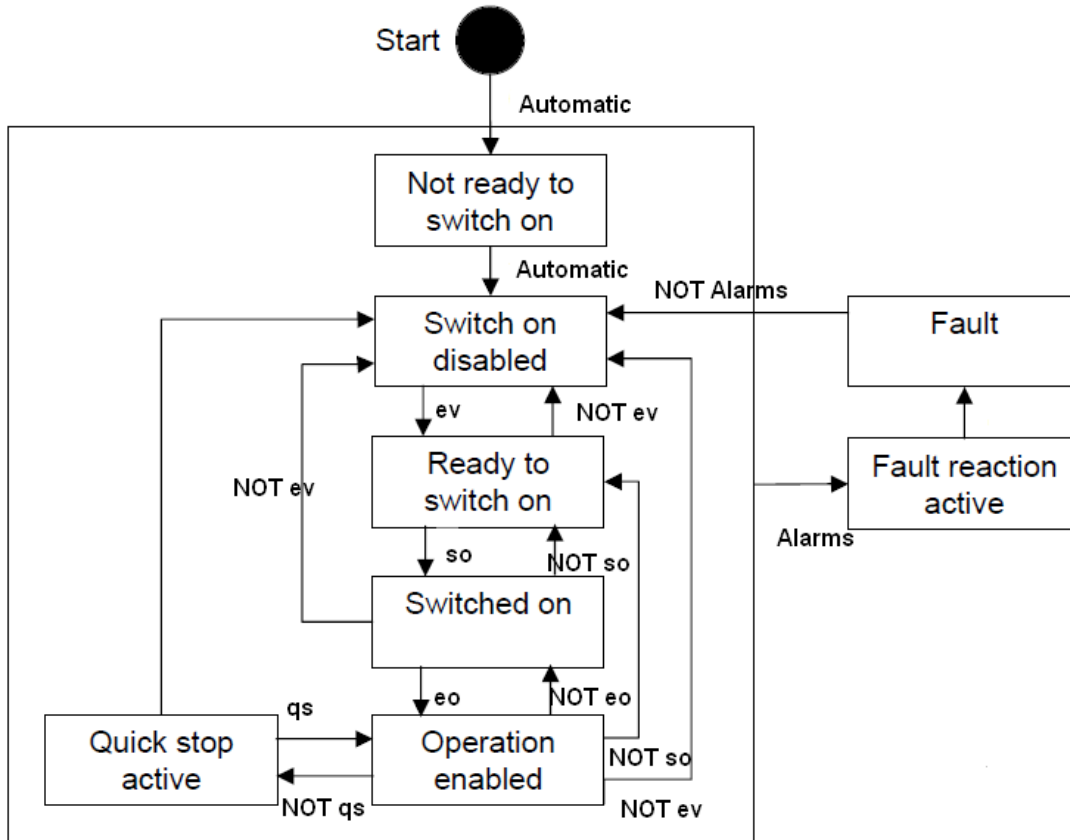

### 2.3.3 EXTRA VIEW

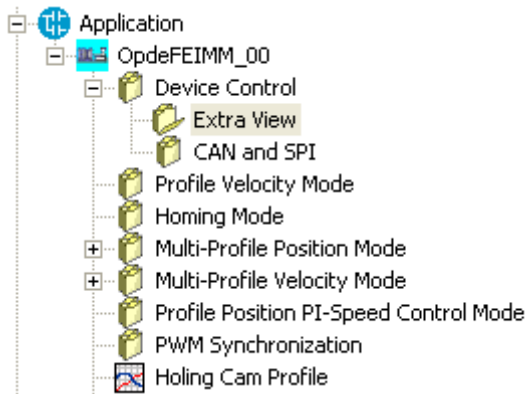

Extra view interface shows some usefully Only-Reading parameters calculated during Multi-Profile Position.

Name	Description	Min	Max	Default	UM	Scale	index	Type	Access
REVISION_HISTORY	E102 – Application Revision History						CAN: 0x3100 sub 0x0b	INTEGER3 2	R
							MODBUS: 0x2002		
MAX_SPEED_IE	D72-D73 - Speed Max [ie] (P65 MOT_MAX_SPEED)				ie		0x2003 sub 0x48- 0x49	INTEGER1 6	R
							0x03c8 – 0x03c9		
MAX_SPEED_POS	E200 - 201 - Maximum positive speed				ie/s		0x3100 sub 0x0c	INTEGER3 2	R
							0x2064- 2065		
MAX_SPEED_NEG	E202 - 203 - Maximum negative speed				ie/s		0x3100 sub 0x0d	INTEGER3 2	R
							0x2066- 2067		
ACT_TIME_TOTAL	E214 - 215 - Total During Time				ms		0x3100 sub 0x09	INTEGER3 2	R
							0x2072- 2073		
ACT_POW_TOT	E216 - 217 - Active total power delivered				Wh	1000	0x3100 sub 0x0a	INTEGER3 2	R
							0x2074- 2075		

Tab. 5- Extra View

## 2.3.4 CAN2 AND SPI

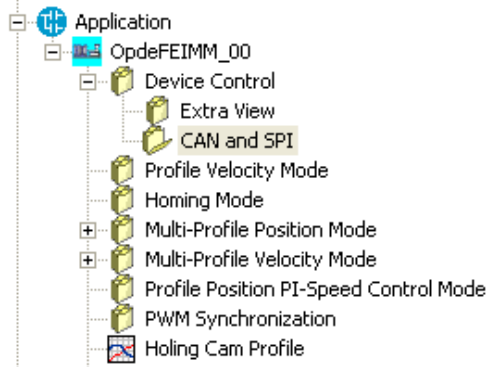

FEIMM can use SPI or CAN2 Communication for send the data between the drives. In the 300 Ton FEIMM the Injection Master send to Injection slave the torque reference and to Screw the actual position, this configuration could be realized with Analogue Input / CAN2 or with SPI.

Name	Description	Min	Max	Default	UM	Scale	index	Type	Access
Comm_Sel	E899 - Communication selection	Range		0 - Use motor position		1	MODBUS: 0x231F	INTEGER16	R/W
		0	0 - Use motor position						
		1	1 - Send Pos by CAN 2						
		2	2 - Receive position by CAN 2						
		3	3 - Send Torque and position by SPI (Master)						
4	4 - Receive Pos by SPI (Slave)								
CAN2_TX_ID	E900 – Transmitter CAN2 Address	0	127				0x2320	INTEGER16	R/W
CAN2_RX_ID	E901 – Receiver CAN2 Address	0	127				0x2321	INTEGER16	R/W
SPI_BAUD_RATE	E45 – SPI Baud Rate	5 - 6.25 Mbit/s	20 - 1.79 Mbit/s	12 - 2.88 Mbit/s	Mbit/s		CAN: 0x201E sub 0x2d MODBUS: 0x0159	INTEGER16	R/W
THR_ALARM_COM	E46 – Threshold time for alarm communication	0,1	300,0	10,0	ms		0x201E sub 0x2e 0x015a	INTEGER16	R/W
ACTUALPOS_2	D75 – D76 – Position received from CAN2 / SPI						0x2003 sub 0x4b - 0x4c 0x03cb-0x03cd	INTEGER16	R
CRC_ERROR_MAX	D86 – Maximum CRC error counter (SPI)						0x2003 sub 0x56 0x03d6	INTEGER16	R
NOT_RECEIVED_MAX	D87 – Maximum losing communication counter (SPI)						0x2003 sub 0x57 0x03d7	INTEGER16	R

Tab. 6- CAN2 and SPI parameters and Objects

Fig. 5 shows the configuration with Analogue Input/Output and CAN2. Fig. 6 shows the configuration with SPI.

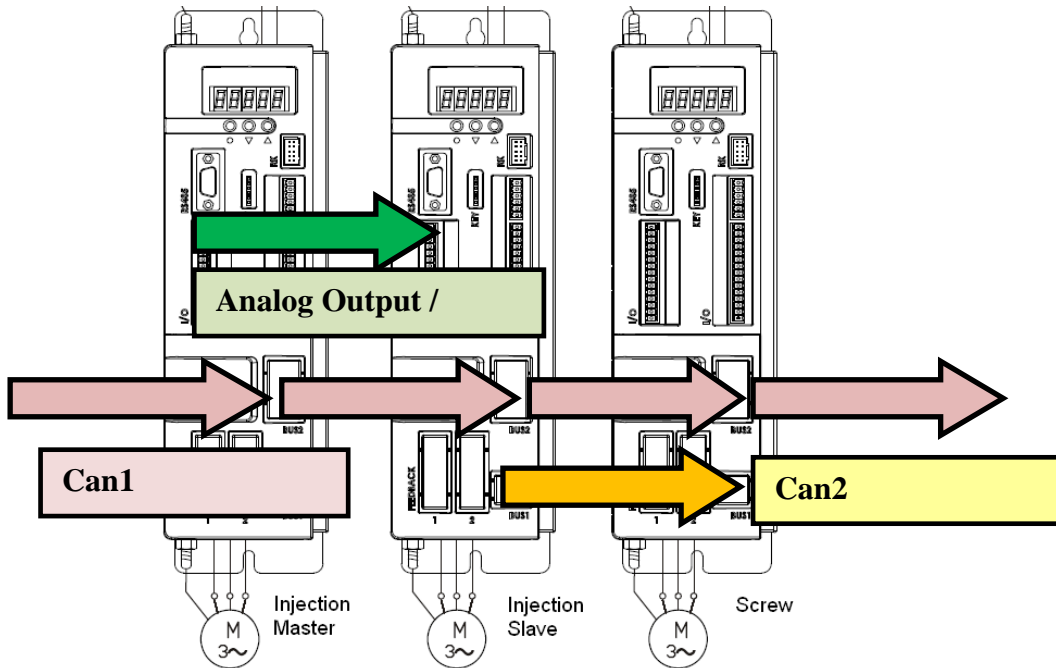

Fig. 5-300 Ton machine configuration with Analogue Input/Output and CAN2

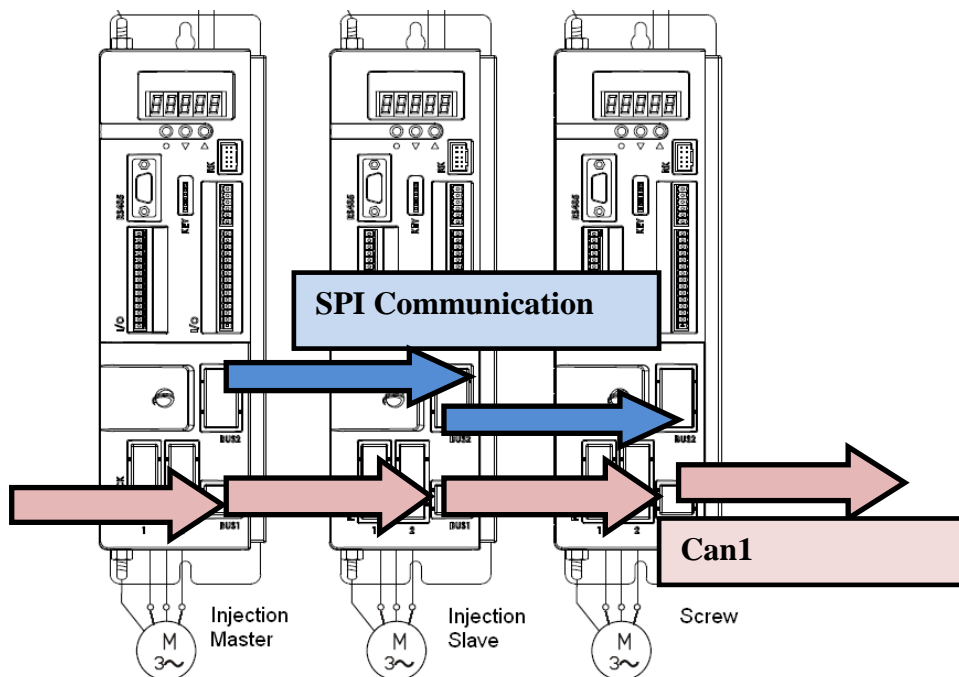

Fig. 6-300 Ton machine configuration with SPI configuration

At the end of Injection, Screw motor starts to run and the change of speeds depends on the position received from Injection Drive by second line CAN.

Parameters **Can2\_Tx\_COB\_ID** and **Can2\_Rx\_COB\_ID** are the transmitter and receiver COB\_ID.  
Parameter **Comm\_Selection** allows to send and receive the position:

- *0-Use Motor Position*: the drive use the position read from the sensor in **Multi Profile Position Mode** and don't send it,
- *1-Use Motor Position and send it*: the drive send the position and use the motor position red from the sensor in **Multi Profile Position Mode** (Injection Axes),
- *2-Use position received from CAN2*: the drive use the position received from CAN2 in **Multi Profile Velocity Mode** (Screw Axes),
- *3-Send Torque and position by SPI* (Master),
- *4-Receive position by SPI* (Slave).

## 2.4 PROFILE VELOCITY MODE

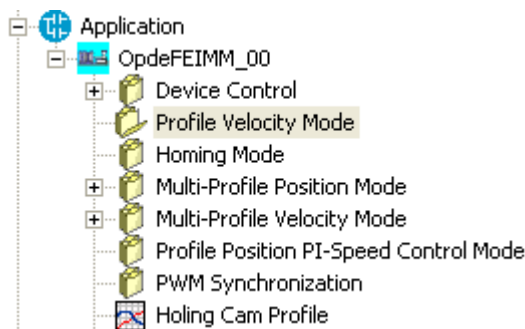

The profile velocity mode covers the following sub-functions:

- Demand value input via trajectory generator;
- Velocity capture using position sensor or velocity sensor;
- Velocity control function with appropriate input and output signals;
- Monitoring of the profile velocity using a window-function;
- Monitoring of velocity actual value using a threshold.

OPDE drive supports the following Profile Velocity Mode objects :

Name	Description	Min	Max	Default	UM	Scale	index	Type	Access
rCONTROL_WORD	E100 – Control Word			0000		1	CAN: 0x6040	UNSIGNED D16	R/W
							MODBUS: 0x2000		
STATUS_WORD	d64 – Status Word			0000		1	0x6041	UNSIGNED D16	R/W
							0x03C0		
RD_STATE_MACHINE	E101 – Finite State Machine					1		UNSIGNED D16	R
							0x2001		
pMODE_OF_OP	E01 – Mode of operations	Range		3		1	0x6060	INTEGER8	R/W
		1	1-Profile Position Mode						
		2	2-Multi Profile Position Mode						
		3	3-Profile Velocity Mode				0x012D		

Name	Description	Min	Max	Default	UM	Scale	index	Type	Access
		4	4-Profile Velocity Mode with PI control						
		6	6-Homing mode						
MODE_OF_OP_DIS	d65 – Modes of operation display						0x6061 0x03C1	INTEGER8	R
pTARGETVEL	E02-E03 - Target velocity	- 21474 83648	214748364 7	32768	ie/s	1	0x3102 sub 0x01 0x012E – 0x012F	INTEGER3 2	R/W
pPROFACC	E04-E05 - Profile acceleration	10223	214748364 7	50000 0	ie/s <sup>2</sup>	1	0x3102 sub 0x02 0x0130 – 0x0131	INTEGER3 2	R/W
pPROFDEC	E06-E07 - Profile deceleration	10223	214748364 7	50000 0	ie/s <sup>2</sup>	1	0x3102 sub 0x03 0x0132 – 0x0133	INTEGER3 2	R/W
pQSDEC	E08 – 09 – Quick stop deceleration	10223	214748364 7	16384 00	ie/s <sup>2</sup>	1	0x3102 sub 0x04 0x0134 – 0x0135	INTEGER3 2	R/W
pQSOPTC	E38 – Quick Stop Option Code	Range							R/W
		0							
		2	2 – Switch On Disabled						
		6	6 – Stay in Quick Stop						
		8					0x3102 sub 0x13 (16 lsb)	INTEGER3 2	
							0x0152	NTEGER3 2	
pTHRVEL	E18 - Velocity threshold	100	65535	10000			0x3102 sub 0x09 (16 lsb) 0x013E	NTEGER3 2	R/W
pTIMEVEL	E20 - Velocity threshold time	0	65535	0	ms	1	0x3102 sub 0x0A (16 lsb) 0x0140	NTEGER3 2	R/W
pWINVEL	E22 - Velocity window	0	65535	0		1	0x3102 sub 0x0B (16 lsb) 0x0142	NTEGER3 2	R/W
pWTIMEVEL	E24 - Velocity window time-out	0	65535	0	ms	1	0x3102 sub 0x0C (16 lsb) 0x0144	NTEGER3 2	R/W
ACTUALPOS	d66-67 – Position actual value				ie		0x6064 0x03C2 - 0x03C3	INTEGER 32	R
ACTUALVEL	d68-69 – Velocity actual value				ie/s		0x606C 0x03C4 - 0x03C5	INTEGER3 2	R
pENSPDFDW	E36 - Enable Speed Feed-forward	0	1	1		1	0x3102 sub 0x18 (16 lsb) 0x0150	NTEGER3 2	R/W
MAX_SPEED_IE	d72-73 – Speed Max [ie] (P65 – MOT_MAX_SPEED)				ie/s		0x200F sub 0x48 0x03C8 – 0x03C9	INTEGER3 2	R

Tab. 7- Device Control Parameters and Objects

## 2.5 HOMING MODE

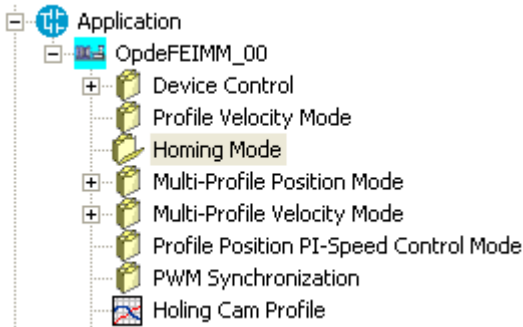

Homing Mode implements the methods which a drive seeks the home position, or initial reference point (also called, the datum or zero point). There are three methods of achieving this using positive/negative torque limits or current position.

OPDE drive supports the following methods:

1. **Homing on current position.** The home position is the current position ;
2. **Homing on Negative Limit Torque (without index).** The home position is at the left of the point where the system finds the negative limit torque ;
3. **Homing on Positive Limit Torque (without index).** The home position is at the left of the point where the home switch changes state;

Name	Description	Min	Max	Default	UM	Scale	index	Type	Access
rCONTROL_WORD	E100 – Control Word			0000		1	CAN: 0x6040 MODBUS: 0x2000	UNSIGNED D16	R/W
STATUS_WORD	d64 – Status Word			0000		1	0x6041 0x03C0	UNSIGNED D16	R/W
RD_STATE_MACHINE	E101 – Finite State Machine					1	0x2001	UNSIGNED D16	R
pMODE_OF_OP	E01 – Mode of operations	Range		3		1	0x6060	INTEGER8	R/W
		1	1-Profile Position Mode						
		2	2-Multi Profile Position Mode						
		3	3-Profile Velocity Mode						
		4	4-Profile Velocity Mode with PI control						
6	6-Homing mode								
6	0x012D								
MODE_OF_OP_DIS	d65 – Modes of operation display					1	0x6061 0x03C1	INTEGER8	R
pHMMODE	E26 - Homing method	1	48	35		1	0x3102 sub 0x0D (16 lsb) 0x0146	INTEGER3 2	R/W
pHMOFFSET	E28-E29 - Home offset	- 21474 83648	214748364 7	0	ie	1	0x3102 sub 0x0E 0x0148- 0x0149	INTEGER3 2	R/W
pHMSPD	E30-E31 - Homing speed during search for switch	0	214748364 7	32768	ie/s	1	0x3102 sub 0x0F	INTEGER3 2	R/W



Name	Description	Min	Max	Default	UM	Scale	index	Type	Access
							0x014A-0x014B		
pHMSPDEND	E32-E33 - Homing speed during search for zero	0	2147483647	32768	ie/s	1	0x3102 sub 0x10 0x014C-0x014D	INTEGER32	R/W
pHMACC	E34-E35 - Homing acceleration	10223	2147483647	500000	ie/s <sup>2</sup>	1	0x3102 sub 0x11 0x014E-0x014F	INTEGER32	R/W
pHMMAXTRQ	E92 - Homing Max Torque	0.00	400.00	400.00	% MOT_T_NOM	100	0x3102 sub 0x2E 0x0188	INTEGER32	R/W
pQSDEC	E08 – 09 – Quick stop deceleration	10223	2147483647	1638400	ie/s <sup>2</sup>	1	0x3102 sub 0x04 0x0134 – 0x0135	INTEGER32	R/W
pQSOPTC	E38 – Quick Stop Option Code	Range				1	0x3102 sub 0x1C (16 lsb) 0x0152	INTEGER32	R/W
		0							
		2	2 – Switch On Disabled						
		6	6 – Stay in Quick Stop						
8									
ACTUALPOS	d66-67 – Position actual value				ie	1	0x6064 0x03C2 - 0x03C3	INTEGER32	R
ACTUALVEL	d68-69 – Velocity actual value				ie/s	1	0x606C 0x03C4 - 0x03C5	INTEGER32	R
MAX_SPEED_IE	d72-73 – Speed Max [ie] (P65 – MOT_MAX_SPEED)				ie/s	1	0x200F sub 0x48 0x03C8 – 0x03C9	INTEGER32	R

Tab. 8- Homing objects

## 2.6 MULTI PROFILE POSITION MODE

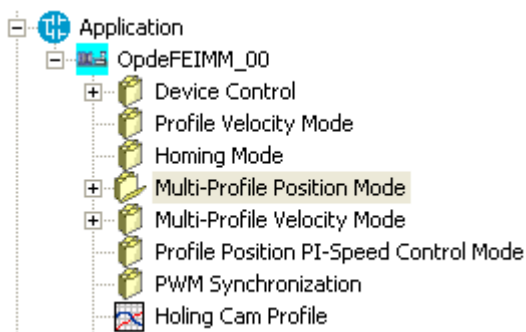

Multi-Profile position mode allows realizing a multi step-speed profile with up to 10 different speeds, the change of the speed depends on the position of the motor. During the positioning, the user can also choose different steps of limit torque. Position Loop is enabled during this operative mode.

The multi-profile position could be Positive or Negative. Only for Negative profile is possible to enable an Holding Cam Profile at the end or during the positioning.

In a FEIMM this operative method can control the following axes:

- Clamp, for open and close the Mould,
- Injector, during the injection (with Holding Cam Profile enabled) and Suck-back (without Holding Cam Profile),
- Ejector, for open and close Ejector

Name	Description	Min	Max	Default	UM	Scale	index	Type	Access
rCONTROL_WORD	E100 – Control Word			0000		1	CAN: 0x6040 MODBUS: 0x2000	UNSIGNED16	R/W
STATUS_WORD	d64 – Status Word			0000		1	0x6041 0x03C0	UNSIGNED16	R/W
RD_STATE_MACHINE	E101 – Finite State Machine					1	0x2001	UNSIGNED16	R
pMODE_OF_OP	E01 – Mode of operations	Range		3		1	0x6060	INTEGER8	R/W
		1	1-Profile Position Mode						
		2	2-Multi Profile Position Mode						
		3	3-Profile Velocity Mode						
		4	4-Profile Velocity Mode with PI control						
6	6-Homing mode								
MODE_OF_OP_DIS	d65 – Modes of operation display					1	0x6061 0x03C1	INTEGER8	R
pQSDEC	E08 – 09 – Quick stop deceleration	10223	2147483647	1638400	ie/s <sup>2</sup>	1	0x3102 sub 0x04 0x0134 – 0x0135	INTEGER32	R/W
pQSOPTC	E38 – Quick Stop Option Code	Range				1	0x3102 sub 0x13 (16 lsb)	INTEGER32	R/W
		0							
		2	2 – Switch On						

Name	Description	Min	Max	Default	UM	Scale	index	Type	Access
		6	Disabled 6 – Stay in Quick Stop				0x0152		
		8							
pTRQPOS_RAMPS	E10 – Positive Torque acc/dec ramps	0.1	6500.0	655.0	ms		0x3102 sub 0x05 (16 lsb) 0x0136	INTEGER3 2	R/W
pTRQNEG_RAMPS	E11 – Negative Torque acc/dec ramps	0.1	6500.0	655.0	ms		0x3102 sub 0x05 (16 msb) 0x0137	INTEGER3 2	R/W
pWINPOS	E14-E15 - Position window	0	2147483647	0	ie	1	0x3102 sub 0x07 0x013A – 0x013B	NTEGER3 2	R/W
pFOLLERR	E16-E17 - Following error window	0	2147483647	0	ie	1	0x3102 sub 0x08 0x013C – 0x013D	NTEGER3 2	R/W
pTHRVEL	E18 - Velocity threshold	100	65535	10000	ie/s	1	0x3102 sub 0x09 (16 lsb) 0x013E	NTEGER3 2	R/W
pTIMEVEL	E20 - Velocity threshold time	0	65535	0	ms	1	0x3102 sub 0x0A (16 lsb) 0x0140	NTEGER3 2	R/W
pWINVEL	E22 - Velocity window	0	65535	0	ie/s	1	0x3102 sub 0x0B (16 lsb) 0x0142	NTEGER3 2	R/W
pWTIMEVEL	E24 - Velocity window time-out	0	65535	0	ms	1	0x3102 sub 0x0C (16 lsb) 0x0144	NTEGER3 2	R/W
pTHREVEL_FILTER_TF	E44 – First order filter time constant on actual velocity	0.1	200.0	100.0	ms		0x3102 sub 0x16 (16 lsb) 0x0142	NTEGER3 2	R/W
ACTUALPOS	d66-67 – Position actual value				ie	1	0x6064 0x03C2 - 0x03C3	INTEGER 32	R
ACTUALVEL	d68-69 – Velocity actual value				ie/s	1	0x606C 0x03C4 - 0x03C5	INTEGER3 2	R
ERRORPOS	d70-d71 Following error actual value				ie	1	0x60F4 0x03C6 – 0x03C7	INTEGER3 2	R
MAX_SPEED_IE	d72-73 – Speed Max [ie] (P65 – MOT_MAX_SPEED)				ie/s	1	0x200F sub 0x48 0x03C8 – 0x03C9	INTEGER3 2	R
pENSPDFDW	E36 - Enable Speed Feed-forward	0	1	1		1	0x3102 sub 0x12 (16 lsb) 0x0150	INTEGER3 2	R/W
pENTRQFDW	E37 - Enable Torque Feed-forward	0	1	1		1	0x3102 sub 0x12 (16 msb)	INTEGER3 2	R/W

Name	Description	Min	Max	Default	UM	Scale	index	Type	Access
							0x0151		
pPOS_REG_KP	E39 - Kv position loop proportional gain	0.0	100.0	4.0		10	0x3102 sub 0x13 (16 msb)	INTEGER3 2	R/W
							0x0153		
PrfPP_Pos_PosTrg	E448 - 449 - Positive Profile Position Target	- 21474 83648	214748364 7	0	ie	1	0x3006 sub 0x00	INTEGER3 2	R
							0x215C – 0x215d		
PrfPP_Neg_Sel_End_Trq	E749 - Profile Negative - Type Switch mode	Range							
		0	0 - None						
		1	1 – Target reach locking						
		2	2 – Target reach holding start CAM profile						
		3	3 - Pos start holding CAM profile						
		4	4 – Pos and trq start holding CAM profile						
		5	5 – Pos and AI start holding CAM profile						
6	6- Pos and DI start holding cam profile								
							0x301C sub 0x004	NTEGER3 2	
							0x2289		R/W
PrfPP_Pos_PosTrg	E704 - 705 - Profile Negative Position Target	- 21474 83648	214748364 7	0	ie	1	0x3016	INTEGER3 2	R
							0x225C – 0x225D		
pSWLIMITMIN	E40 – 41 – Min Position Limit	- 21474 83648	214748364 7	0	ie	1	0x3102 sub 0x20	NTEGER3 2	R/W
							0x2400		
pSWLIMITMAX	E42 – 43 – Max Position limit	- 21474 83648	214748364 7	0	ie	1	0x3102 sub 0x21	NTEGER3 2	R/W
							0x2401		

**Tab. 9- Device Control Parameters and Objects**

Position loop works in the way shows in the **Fig. 7**. Error position is multiply by **E39 - pPOS\_REG\_KP** and give an additional speed reference (in pulses) to speed regulator. Speed Feed-forward can be enabled with **E36-pENSPDFDW**. Eventually also a Torque Feed-forward can be enabled with **E37-pENTRQFDW**.

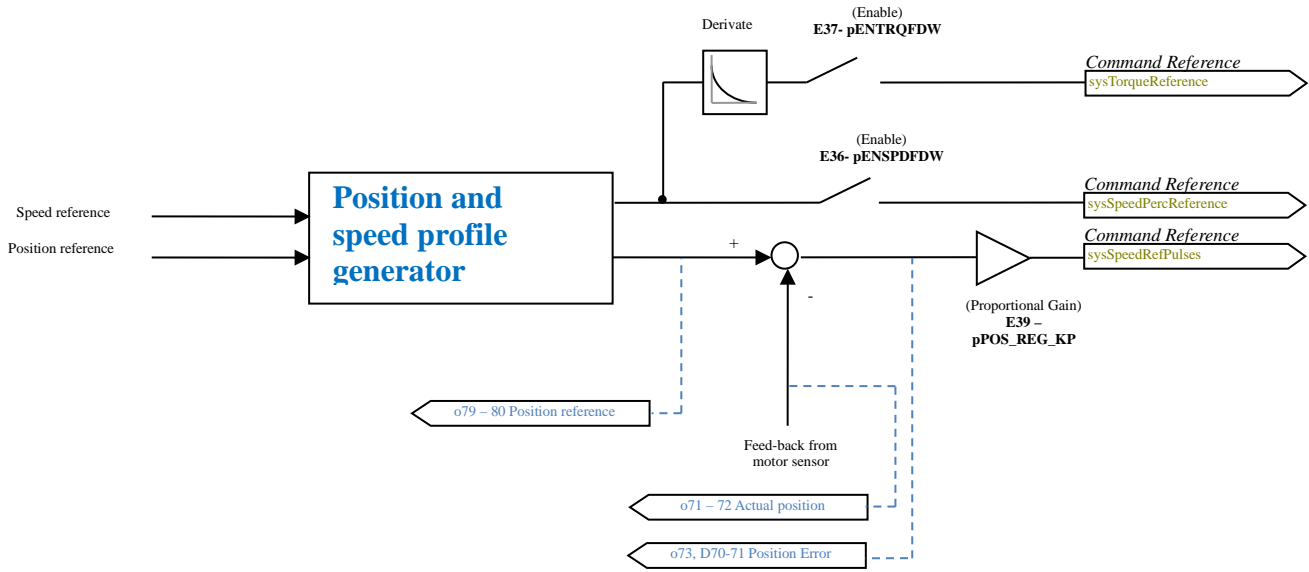

**Fig. 7-Multi-Profile position loop**

If position error (*d70-71 ERRORPOS, o73-Absolute position error*), becomes greater than threshold **E16-17 – pFOLLERR** the drive trips in alarm **A4.2**.

When, at the end of positioning, the real position is inside the position reference with threshold **E14-15 – pWINPOS**, the bit 10 of STATUS WORD "Target Reached" is enabled.

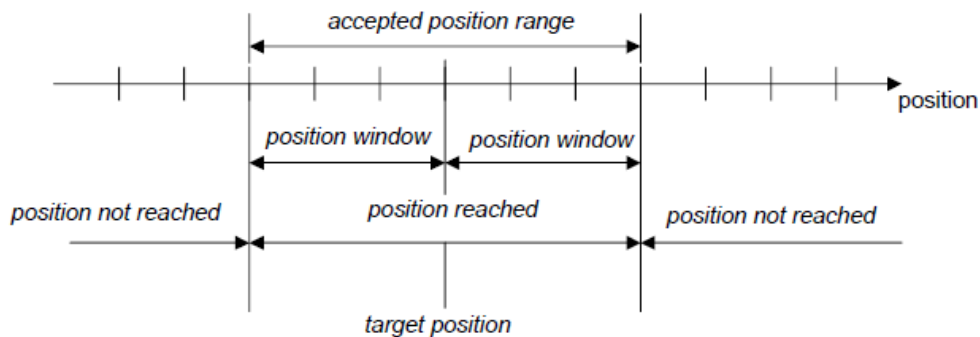

**Fig. 8-Target Reached Position**

## 2.6.1 PROFILE POSITIVE

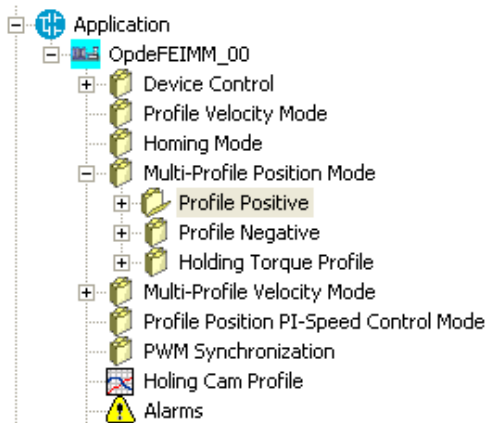

Multi Profile Position Positive can be enabled with bit 10 of control word Fig. 1, Tab. 2 or with logical input I11 – Profile positive start enable.

Name	Description	Min	Max	Default	UM	Scale	index	Type	Access
rCONTROL_WORD	E100 – Control Word			0000		1	CAN: 0x6040 MODBUS: 0x2000	UNSIGNED D16	R/W
STATUS_WORD	d64 – Status Word			0000		1	0x6041 0x03C0	UNSIGNED D16	R/W
RD_STATE_MACHINE	E101 – Finite state automation						0x2001	INTEGER1 6	R
pMODE_OF_OP	E01 – Mode of operations	Range		3		1	0x6060	INTEGER8	R/W
		1	1-Profile Position Mode						
		2	2-Multi Profile Position Mode						
		3	3-Profile Velocity Mode						
		4	4-Profile Velocity Mode with PI control						
6	6-Homing mode								
MODE_OF_OP_DIS	d65 – Modes of operation display						0x6061 0x03C1	INTEGER8	R
PrfPP_Pos_PosTrg	E448 - 449 - Positive Profile Position Target	- 21474 83648	214748364 7	0	ie	1	0x3006 sub 0x00 0x215C – 0x215D	INTEGER3 2	R
PrfPP_Pos_EndSpdRef	E450 - 451 - Profile Positive End Speed Open Loop	0	214748364 7	0	ie/s	1	0x3007 sub 0x00 0x215E	INTEGER3 2	R/W
MAX_SPEED_IE	d72-73 – Speed Max [ie] (P65 – MOT_MAX_SPEED)				ie/s		0x200F sub 0x48 0x03C8 – 0x03C9	INTEGER3 2	R
MAX_SPEED_POS	E200-201 – Maximum Positive speed				ie	1	0x3100 sub 0x0c 0x2064- 0x2065	INTEGER3 2	R

Tab. 10- Multi Profile Positive Parameters and Objects

## 2.6.1.0 Speed Positive Profile

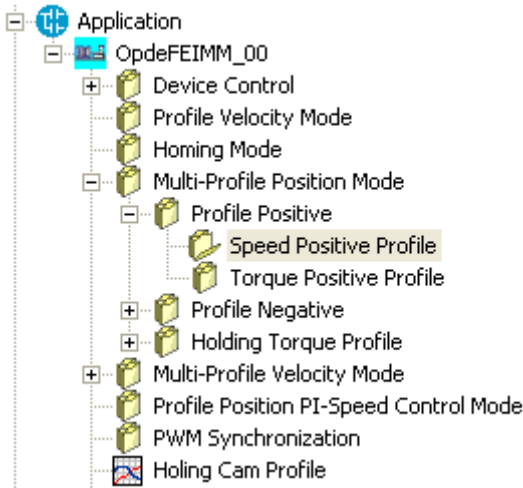

Table **Tab. 11** shows the 10 positions for change the speed (**PrfPP\_Pos\_PosChgSpd\_0..... PrfPP\_Pos\_PosChgSpd\_9**) and 10 speeds (**PrfPP\_Pos\_Speed\_0.... PrfPP\_Pos\_Speed\_9**). Parameters **PrfPP\_Pos\_NrPrfSpd** and **PrfPP\_Pos\_IndTrgPos** set the numbers of the change of speed for the profile.

Name	Description	Min	Max	Default	UM	Scale	index	Type	Access
PrfPP_Pos_PosChgSpd_0	E356 - 357 - 0 - Positive Profile Position Targhet/Change Speed	-	2147483648	0	ie	1	CAN: 0x3000 sub 0x00	INTEGER32	R/W
							MODBUS: 0x2100- 0x2101		
PrfPP_Pos_PosChgSpd_1	E358 - 359 - 1 - Positive Profile Position Targhet/Change Speed	-	2147483648	0	ie	1	0x3000 sub 0x01	INTEGER32	R/W
							0x2102- 0x2103		
PrfPP_Pos_PosChgSpd_2	E360 - 361 - 2 - Positive Profile Position Targhet/Change Speed	-	2147483648	0	ie	1	0x3000 sub 0x02	INTEGER32	R/W
							0x2104- 0x2105		
PrfPP_Pos_PosChgSpd_3	E362 - 363 - 3 - Positive Profile Position Targhet/Change Speed	-	2147483648	0	ie	1	0x3000 sub 0x03	INTEGER32	R/W
							0x2106- 0x2107		
PrfPP_Pos_PosChgSpd_4	E364 - 365 - 4 - Positive Profile Position Targhet/Change Speed	-	2147483648	0	ie	1	0x3000 sub 0x04	INTEGER32	R/W
							0x2108- 0x2109		
PrfPP_Pos_PosChgSpd_5	E366 - 367 - 5 - Positive Profile Position Targhet/Change Speed	-	2147483648	0	ie	1	0x3000 sub 0x05	INTEGER32	R/W
							0x210A- 0x210B		
PrfPP_Pos_PosChgSpd_6	E368 - 369 - 6 - Positive Profile Position Targhet/Change Speed	-	2147483648	0	ie	1	0x3000 sub 0x06	INTEGER32	R/W
							0x210C- 0x210D		
PrfPP_Pos_PosChgSpd_7	E370 - 371 - 7 - Positive Profile Position Targhet/Change Speed	-	2147483648	0	ie	1	0x3000 sub 0x07	INTEGER32	R/W
							0x210E- 0x210F		
PrfPP_Pos_PosChgSpd_8	E372 - 373 - 8 - Positive Profile Position	-	2147483648	0	ie	1	0x3000 sub 0x08	INTEGER32	R/W

Name	Description	Min	Max	Default	UM	Scale	index	Type	Access
	Targhet/Change Speed						0x2110-0x2111		
PrfPP_Pos_Pos ChgSpd_9	E374 - 375 - 9 - Positive Profile Position Targhet/Change Speed	-	2147483647	0	ie	1	0x3000 sub 0x08	INTEGER32	R/W
							0x2112-0x2113		
PrfPP_Pos_Sped_0	E378 - 379 - 0 - Profile Positive Speed	0	2147483647	0	ie/s	1	0x3001 sub 0x00	INTEGER32	R/W
							0x2116-0x2117		
PrfPP_Pos_Sped_1	E380 - 381 - 1 - Profile Positive Speed	0	2147483647	0	ie/s	1	0x3001 sub 0x01	INTEGER32	R/W
							0x2118-0x2119		
PrfPP_Pos_Sped_2	E382 - 383 - 2 - Profile Positive Speed	0	2147483647	0	ie/s	1	0x3001 sub 0x02	INTEGER32	R/W
							0x211A-0x211B		
PrfPP_Pos_Sped_3	E384 - 385 - 3 - Profile Positive Speed	0	2147483647	0	ie/s	1	0x3001 sub 0x03	INTEGER32	R/W
							0x211C-0x211D		
PrfPP_Pos_Sped_4	E386 - 387 - 4 - Profile Positive Speed	0	2147483647	0	ie/s	1	0x3001 sub 0x04	INTEGER32	R/W
							0x211E-0x211F		
PrfPP_Pos_Sped_5	E388 - 389 - 5 - Profile Positive Speed	0	2147483647	0	ie/s	1	0x3001 sub 0x05	INTEGER32	R/W
							0x2120-0x2121		
PrfPP_Pos_Sped_6	E390 - 391 - 6 - Profile Positive Speed	0	2147483647	0	ie/s	1	0x3001 sub 0x06	INTEGER32	R/W
							0x2122-0x2123		
PrfPP_Pos_Sped_7	E392 - 393 - 7 - Profile Positive Speed	0	2147483647	0	ie/s	1	0x3001 sub 0x07	INTEGER32	R/W
							0x2124-0x2125		
PrfPP_Pos_Sped_8	E394 - 395 - 8 - Profile Positive Speed	0	2147483647	0	ie/s	1	0x3001 sub 0x08	INTEGER32	R/W
							0x2126-0x2127		
PrfPP_Pos_Sped_9	E396 - 397 - 9 - Profile Positive Speed	0	2147483647	0	ie/s	1	0x3001 sub 0x09	INTEGER32	R/W
							0x2128-0x2129		
PrfPP_Pos_Acc_Dec_0	E510 – 511 – Positive Profile Acc Dec 0	10223	2147483647	500000	ie/s <sup>2</sup>	1	0x300a sub 0x00	INTEGER32	R/W
							0x219a – 0x219b		
PrfPP_Pos_Acc_Dec_1	E512 – 513 – Positive Profile Acc Dec 1	10223	2147483647	500000	ie/s <sup>2</sup>	1	0x300a sub 0x01	INTEGER32	R/W
							0x219c – 0x219d		
PrfPP_Pos_Acc_Dec_2	E514 – 515 – Positive Profile Acc Dec 2	10223	2147483647	500000	ie/s <sup>2</sup>	1	0x300a sub 0x02	INTEGER32	R/W
							0x219e – 0x219f		
PrfPP_Pos_Acc_Dec_3	E516 – 517 – Positive Profile Acc Dec 3	10223	2147483647	500000	ie/s <sup>2</sup>	1	0x300a sub 0x03	INTEGER32	R/W
							0x21a0 – 0x21a1		
PrfPP_Pos_Acc	E518 – 519 – Positive Profile	10223	2147483647	5000	ie/s <sup>2</sup>	1	0x300a sub	INTEGER32	R/W



Name	Description	Min	Max	Default	UM	Scale	index	Type	Access
_Dec_4	Acc Dec 4		647	00			0x04		
							0x21a2 – 0x21a3		
PrfPP_Pos_Acc _Dec_5	E520 – 521 – Positive Profile Acc Dec 5	10223	2147483 647	5000 00	ie/s <sup>2</sup>	1	0x300a sub 0x05	INTEGER32	R/W
							0x21a4 – 0x21a5		
PrfPP_Pos_Acc _Dec_6	E522 – 523 – Positive Profile Acc Dec 6	10223	2147483 647	5000 00	ie/s <sup>2</sup>	1	0x300a sub 0x06	INTEGER32	R/W
							0x21a6 – 0x21a7		
PrfPP_Pos_Acc _Dec_7	E524 – 525 – Positive Profile Acc Dec 7	10223	2147483 647	5000 00	ie/s <sup>2</sup>	1	0x300a sub 0x07	INTEGER32	R/W
							0x21a8 – 0x21a9		
PrfPP_Pos_Acc _Dec_8	E526 – 527 – Positive Profile Acc Dec 8	10223	2147483 647	5000 00	ie/s <sup>2</sup>	1	0x300a sub 0x08	INTEGER32	R/W
							0x21aa – 0x21ab		
PrfPP_Pos_Acc _Dec_9	E528 – 529 – Positive Profile Acc Dec 9	10223	2147483 647	5000 00	ie/s <sup>2</sup>	1	0x300a sub 0x09	INTEGER32	R/W
							0x21ac – 0x21ad		
PrfPP_Pos_Fina l_Dec	E530 – 531 – Positive Profile Acc Dec 4	10223	2147483 647	5000 00	ie/s <sup>2</sup>	1	0x300a sub 0x0a		R/W
							0x21ae – 0x21af		
PrfPP_Pos_NrPr fSpd	E400 - Positive Profile Nr. Change Speed	0	8	0		1	0x300C sub 0x01	INTEGER 8	R/W
							0x212C		
MAX_SPEED_I E	d72-73 – Speed Max [ie] (P65 – MOT_MAX_SPEED)				ie/s		0x200F sub 0x48		R
							0x03C9 – 0x03C9		
PrfPP_Pos_IndT rgPos	E401 - Index of Positive Profile Position Targhet	0	9	9		1	0x300C sub 0x00	INTEGER 8	R/W
							0x212D		

Tab. 11- Multi-profile Positive Speed parameters and Objects

## 2.6.1.1 Torque Positive Profile

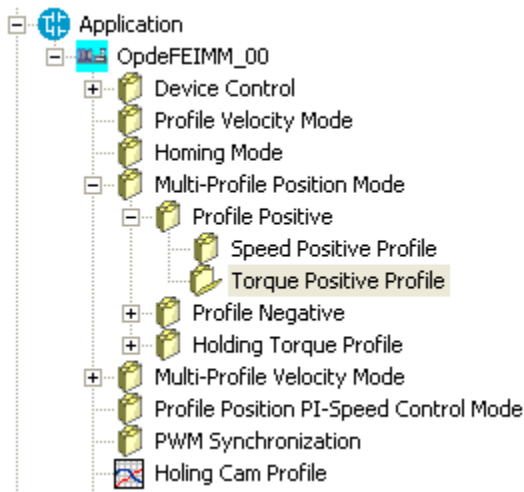

Table **Tab. 12** shows the 9 positions for change the speed (**PrfPP\_Pos\_PosChgTrq\_0.... PrfPP\_Pos\_PosChgTrq\_9**) and 10 speeds (**PrfPP\_Pos\_Torque\_0.... PrfPP\_Pos\_Torque\_1**).  
Parameter **PrfPP\_Pos\_NrPrfTrq** allows to choose the numbers of the change of torque limits for the profile.

Name	Description	Min	Max	Default	UM	Scale	index	Type	Access
PrfPP_Pos_PosChgTrq_0	E402 - 403 - 0 - Profile Positive Position Change Torque	-	2147483648	0	ie	1	CAN: 0x3003 sub 0x00	INTEGER32	R/W
							MODBUS: 0x212E- 0x212F		
PrfPP_Pos_PosChgTrq_1	E404 - 405 - 1 - Profile Positive Position Change Torque	-	2147483648	0	ie	1	0x3003 sub 0x01	INTEGER32	R/W
							0x2130- 0x2131		
PrfPP_Pos_PosChgTrq_2	E406 - 407 - 2 - Profile Positive Position Change Torque	-	2147483648	0	ie	1	0x3003 sub 0x02	INTEGER32	R/W
							0x2132- 0x2133		
PrfPP_Pos_PosChgTrq_3	E408 - 409 - 3 - Profile Positive Position Change Torque	-	2147483648	0	ie	1	0x3003 sub 0x03	INTEGER32	R/W
							0x2134- 0x2135		
PrfPP_Pos_PosChgTrq_4	E410 - 411 - 4 - Profile Positive Position Change Torque	-	2147483648	0	ie	1	0x3003 sub 0x04	INTEGER32	R/W
							0x2136- 0x2137		
PrfPP_Pos_PosChgTrq_5	E412 - 413 - 5 - Profile Positive Position Change Torque	-	2147483648	0	ie	1	0x3003 sub 0x05	INTEGER32	R/W
							0x2138- 0x2139		
PrfPP_Pos_PosChgTrq_6	E414 - 415 - 6 - Profile Positive Position Change Torque	-	2147483648	0	ie	1	0x3003 sub 0x06	INTEGER32	R/W
							0x213A- 0x213B		
PrfPP_Pos_PosChgTrq_7	E416 - 417 - 7 - Profile Positive Position Change Torque	-	2147483648	0	ie	1	0x3003 sub 0x07	INTEGER32	R/W

Name	Description	Min	Max	Default	UM	Scale	index	Type	Access
	Torque						0x213C-0x213D		
PrfPP_Pos_PosChgTrq_8	E418 - 419 - 8 - Profile Positive Position Change Torque	-2147483648	2147483647	0	ie	1	0x3003 sub 0x08 0x213E-0x213F	INTEGER32	R/W
PrfPP_Pos_Torque_0	E425 - 0 - Profile Positive Limit Torque	0.00	400.00	0.00	ie	100	0x3004 sub 0x00 0x2145	UNSIGNED 16	R/W
PrfPP_Pos_Torque_1	E426 - 1 - Profile Positive Limit Torque	0.00	400.00	0.00	% MOT_T_NOM	100	0x3004 sub 0x01 0x2146	UNSIGNED 16	R/W
PrfPP_Pos_Torque_2	E427 - 2 - Profile Positive Limit Torque	0.00	400.00	0.00	% MOT_T_NOM	100	0x3004 sub 0x02 0x2147	UNSIGNED 16	R/W
PrfPP_Pos_Torque_3	E428 - 3 - Profile Positive Limit Torque	0.00	400.00	0.00	% MOT_T_NOM	100	0x3004 sub 0x03 0x2148	UNSIGNED 16	R/W
PrfPP_Pos_Torque_4	E429 - 4 - Profile Positive Limit Torque	0.00	400.00	0.00	% MOT_T_NOM	100	0x3004 sub 0x04 0x2149	UNSIGNED 16	R/W
PrfPP_Pos_Torque_5	E430 - 5 - Profile Positive Limit Torque	0.00	400.00	0.00	% MOT_T_NOM	100	0x3004 sub 0x05 0x214A	UNSIGNED 16	R/W
PrfPP_Pos_Torque_6	E431 - 6 - Profile Positive Limit Torque	0.00	400.00	0.00	% MOT_T_NOM	100	0x3004 sub 0x06 0x214B	UNSIGNED 16	R/W
PrfPP_Pos_Torque_7	E432 - 7 - Profile Positive Limit Torque	0.00	400.00	0.00	% MOT_T_NOM	100	0x3004 sub 0x07 0x214C	UNSIGNED 16	R/W
PrfPP_Pos_Torque_8	E433 - 8 - Profile Positive Limit Torque	0.00	400.00	0.00	% MOT_T_NOM	100	0x3004 sub 0x08 0x214D	UNSIGNED 16	R/W
PrfPP_Pos_Torque_9	E434 - 9 - Profile Positive Limit Torque	0.00	400.00	0.00	% MOT_T_NOM	100	0x3004 sub 0x09 0x214E	UNSIGNED 16	R/W
PrfPP_Pos_NrPrfTrq	E447 - Positive Profile Nr. Change Limit Torque	0	8	0		1	0x300C sub 0x02 0x215B	INTEGER8	R/W

**Tab. 12- Change torque Positive Parameters and Objects**

Example 1: **Multi-profile Positive.**

Parameters:

**pPOS\_FRAC** = 23 bit (1 turn = 8388608 ie),  
**PrfPP\_Pos\_NrPrfSpd** = 3,  
**PrfPP\_Pos\_IndTrgPos** = 9,  
**PrfPP\_Pos\_NrPrfTrq** = 9.

PrfPP_Pos_PosChgSpd_0 = 2097152 ie	PrfPP_Pos_Speed_0 = 4194304 ie/s
PrfPP_Pos_PosChgSpd_1 = 4194304 ie	PrfPP_Pos_Speed_1 = 8388608 ie/s
PrfPP_Pos_PosChgSpd_2 = 6291456 ie	PrfPP_Pos_Speed_2 = 12582912 ie/s
PrfPP_Pos_PosChgSpd_3 = 8388608 ie	PrfPP_Pos_Speed_3 = 16777216 ie/s
PrfPP_Pos_PosChgSpd_4 = 10485760 ie	PrfPP_Pos_Speed_4 = 20971520 ie/s

PrfPP_Pos_PosChgSpd_5 = 12582912 ie	PrfPP_Pos_Speed_5 = 25165824 ie/s
PrfPP_Pos_PosChgSpd_6 = 14680064 ie	PrfPP_Pos_Speed_6 = 29360128 ie/s
PrfPP_Pos_PosChgSpd_7 = 16777216 ie	PrfPP_Pos_Speed_7 = 33554432 ie/s
PrfPP_Pos_PosChgSpd_8 = 18874368 ie	PrfPP_Pos_Speed_8 = 37748736 ie/s
PrfPP_Pos_PosChgSpd_9 = 20971520 ie	PrfPP_Pos_Speed_9 = 41943040 ie/s

PrfPP_Pos_PosChgTrq_0 = 2097152 ie	PrfPP_Pos_Torque_0 = 10.00 %
PrfPP_Pos_PosChgTrq_1 = 4194304 ie	PrfPP_Pos_Torque_1 = 20.00 %
PrfPP_Pos_PosChgTrq_2 = 6291456 ie	PrfPP_Pos_Torque_2 = 30.00 %
PrfPP_Pos_PosChgTrq_3 = 8388608 ie	PrfPP_Pos_Torque_3 = 40.00 %
PrfPP_Pos_PosChgTrq_4 = 10485760 ie	PrfPP_Pos_Torque_4 = 50.00 %
PrfPP_Pos_PosChgTrq_5 = 12582912 ie	PrfPP_Pos_Torque_5 = 60.00 %
PrfPP_Pos_PosChgTrq_6 = 14680064 ie	PrfPP_Pos_Torque_6 = 70.00 %
PrfPP_Pos_PosChgTrq_7 = 16777216 ie	PrfPP_Pos_Torque_7 = 24.00 %
PrfPP_Pos_PosChgTrq_8 = 18874368 ie	PrfPP_Pos_Torque_8 = 25.00 %
	PrfPP_Pos_Torque_9 = 50.00 %

With this configurations there are three change of speed ( $PrfPP\_Pos\_NrPrfSpd = 3$ ), starting from  $PrfPP\_Pos\_PosChgSpd\_6$  ( $6 = PrfPP\_Pos\_IndTrgPos = 9 - PrfPP\_Pos\_NrPrfSpd = 3$ ). The three speeds will be 6,7,8,9. There will be also nine change of positive torque limit ( $PrfPP\_Pos\_NrPrfTrq = 9$ ). The nine positive torque limits will be 0,1,2,3,4,5,6,7,8,9.

**Fig. 11 and Errore. L'origine riferimento non è stata trovata.** shows the results when the start positive profile command is given. The blue signal is the speed feed-forward (**sysSpeedPerReference**), the red signal is the positive torque limit (**sysMaxPositiveTorque**). **Fig. 11** shows the steps of torque and speed, **Errore. L'origine riferimento non è stata trovata.** shows the position points for change speed and torque limit.

In this example accelerations have the same value and torque limit is not ramp.

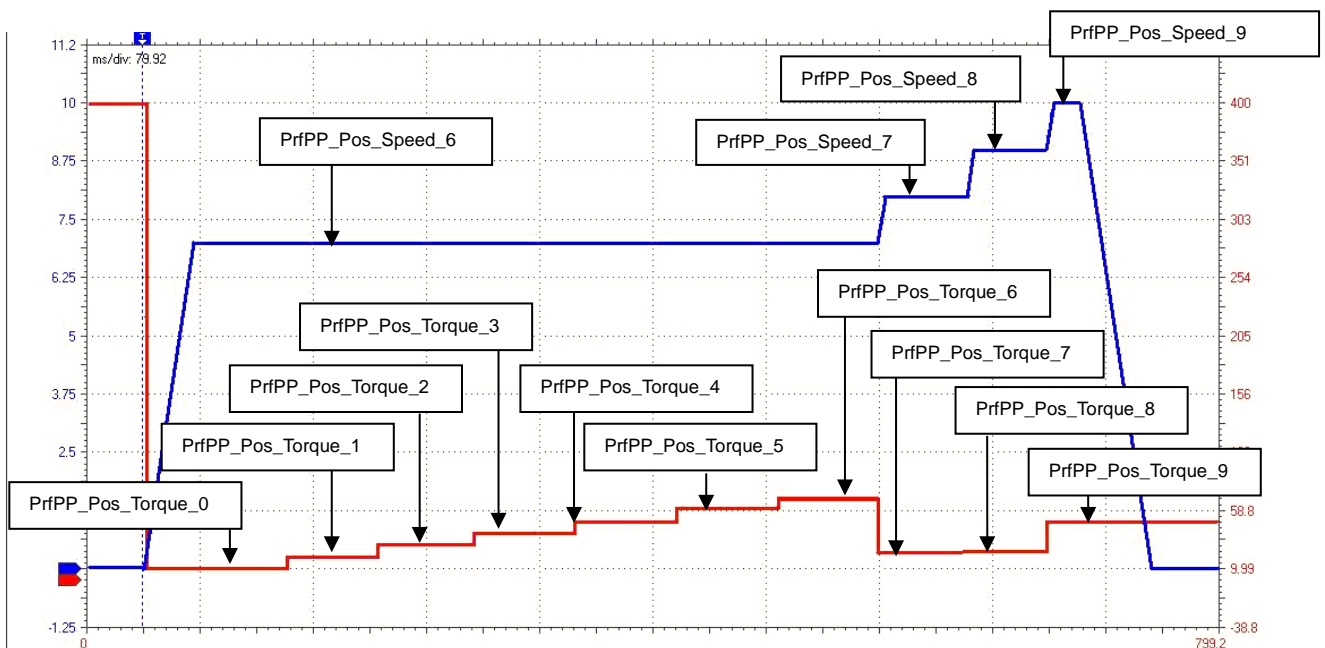

Fig. 9-Torque limit and speed reference

Example 2: Multi-profile Positive.

Parameters:

**pPOS\_FRAC** = 16 bit (1 turn = 65536 ie),  
**PrfPP\_Pos\_NrPrfSpd** = 2,  
**PrfPP\_Pos\_IndTrgPos** = 2,  
**PrfPP\_Pos\_NrPrfTrq** = 2.

**pTRQ\_POS\_RAMPS** = 200.0 ms

PrfPP_Pos_PosChgSpd_0 = 16384 ie	PrfPP_Pos_Speed_0 = 16384 ie/s
PrfPP_Pos_PosChgSpd_1 = 65536 ie	PrfPP_Pos_Speed_1 = 65536 ie/s
PrfPP_Pos_PosChgSpd_2 = 196605 ie	PrfPP_Pos_Speed_2 = 196605 ie/s
.....	
PrfPP_Pos_Acc_Dec_0 = 163840 ie/s <sup>2</sup>	
PrfPP_Pos_Acc_Dec_1 = 655360 ie/s <sup>2</sup>	
PrfPP_Pos_Acc_Dec_2 = 3932100 ie/s <sup>2</sup>	

PrfPP_Pos_PosChgTrq_0 = 32768 ie	PrfPP_Pos_Torque_0 = 70.0 %
PrfPP_Pos_PosChgTrq_1 = 98304 ie	PrfPP_Pos_Torque_1 = 140.0 %
	PrfPP_Pos_Torque_2 = 50.0 %

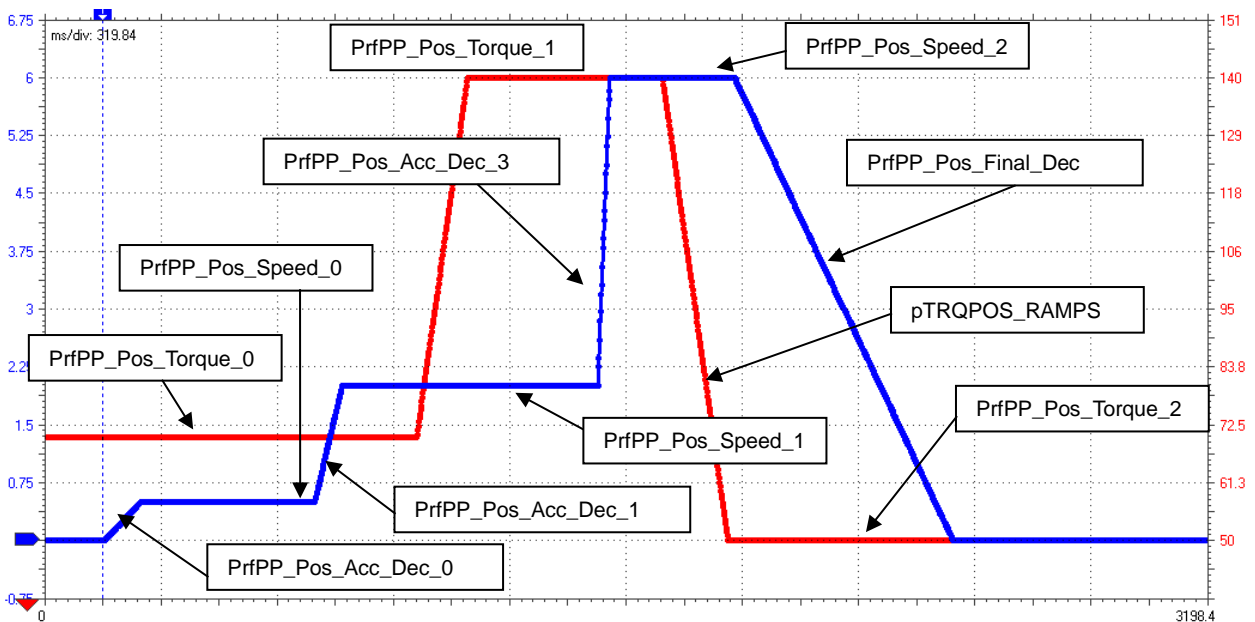

**Fig. 10-Multi-Profile positive Example**

Example 2 shows a Multi-profile positive reference where accelerations have different value, depending on the actual value of index.

The blue signal is the speed feed-forward (**sysSpeedPercReference**), the red one is the positive limit (**sysMaxPositiveTorque**).

The torque limit is ramps with parameter **pTRQPOS\_RAMPS**. The value in ms is referred to 100.00% of nominal torque.

## 2.6.2 PROFILE NEGATIVE

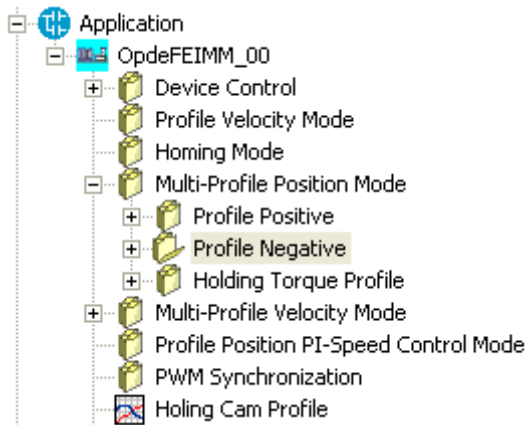

Profile Negative works in the same way of Profile Positive, the references refer to decreasing position (negative speed) and negative torque limit.

Multi Profile Position Negative can be enabled with bit 11 of control word **Fig. 1, Tab. 2** or with logical input **I12 – Profile negative start enable**.

Name	Description	Min	Max	Default	UM	Scale	index	Type	Access
rCONTROL_WORD	E100 – Control Word			0000		1	<b>CAN:</b> 0x6040 <b>MODBUS:</b> 0x2000	UNSIGNED16	R/W
STATUS_WORD	d64 – Status Word			0000		1	0x6041 0x03C0	UNSIGNED16 INTEGER16	R/W
RD_STATE_MACHINE	E101 – Finite State Automation						0x2001		R
pMODE_OF_OP	E01 – Mode of operations	Range		3		1	0x6060	INTEGER8	R/W
		1	1-Profile Position Mode						
		2	2-Multi Profile Position Mode						
		3	3-Profile Velocity Mode						
		4	4-Profile Velocity Mode with PI control						
6	6-Homing mode								
MODE_OF_OP_DIS	d65 – Modes of operation display						0x6061 0x03C1	INTEGER8	R
PrfPP_Neg_PosTrg	E704 - 705 - Profile Negative Position Target	-2147483648	2147483647	0	ie	1	0x3016 0x225C – 0x225d	INTEGER32	R
PrfPP_Neg_Sel_End_Trg	E749 - Profile Negative - Type Switch mode	Range				1	0x301C sub 0x04	INTEGER8	R/W
		0	0 - None						
		1	1 – Target reach locking						
		2	2 – Target reach holding start CAM profile						
		3	3 - Pos start holding CAM profile						
4	4 – Pos and trq								

Name	Description	Min	Max	Default	UM	Scale	index	Type	Access
			start holding CAM profile						
		5	5 – Pos and AI start holding CAM profile						
		6	6- Pos and DI start holding cam profile						
PrfPP_Neg_EndSpdRef	E706 - 707 - Profile Negative End Speed Open Loop	0	2147483647	0	ie/s	1	0x3017 0x225E – 0x225F	INTEGER32	R/W
PrfPP_Neg_SelType_HoldCam	E750 - Profile Neg. Holding Cam Profile Interpolation Type	Range		0			0x301C sub 0x05 0x228A	INTEGER8	R/W
		0	0 - Linear						
		1	1 – S - Ramps						
		2	2 – Cubic Spline						
		3	3 - Bezier						
MAX_SPEED_IE	d72-73 – Speed Max [ie] (P65 – MOT_MAX_SPEED)				ie/s	1	0x200F sub 0x48 0x03C8 – 0x3C9	INTEGER32	R
PrfPP_Neg_PosLimit	E676 – 677 - PrfPP_Neg_PosLimit	-2147483648	2147483647	0	ie		0x3013 sub 0x09 0x2240 – 0x2241	INTEGER32	R/W
MSX_SPEED_NEG	E202-203 – Maximum negative speed				ie/s		0x3100 sub 0x0d 0x2066 – 0x2067	INTEGER32	

Tab. 13- Multi-profile Negative parameters and Objects

### 2.6.2.0 Speed Negative Profile

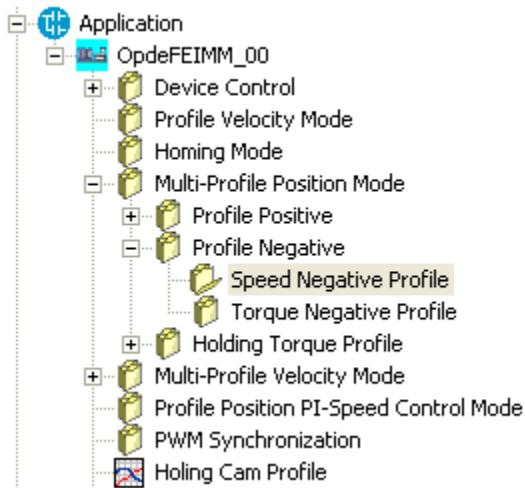

Name	Description	Min	Max	Default	UM	Scale	index	Type	Access
PrfPP_Neg_Pos ChgSpd_0	E612 - 613 - 0 - Negative Profile Position Targhet/Change Speed	-2147483648	2147483647	0	ie	1	CAN: 0x3010 sub 0x00 MODBUS: 0x2200 – 0x2201	INTEGER32	R/W
PrfPP_Neg_Pos ChgSpd_1	E614 - 615 - 1 - Negative Profile Position	-2147483648	2147483647	0	ie	1	0x3010 sub	INTEGER32	R/W

Name	Description	Min	Max	Default	UM	Scale	index	Type	Access
	Targhet/Change Speed						0x01		
							0x2202 – 0x2203		
PrfPP_Neg_Pos ChgSpd_2	E616 - 617 - 2 - Negative Profile Position Targhet/Change Speed	- 2147483648	2147483 647	0	ie	1	0x3010 sub 0x02	INTEGER 32	R/W
							0x2204 – 0x2205		
PrfPP_Neg_Pos ChgSpd_3	E618 - 619 - 3 - Negative Profile Position Targhet/Change Speed	- 2147483648	2147483 647	0	ie	1	0x3010 sub 0x03	INTEGER 32	R/W
							0x2206 – 0x2207		
PrfPP_Neg_Pos ChgSpd_4	E620 - 621 - 4 - Negative Profile Position Targhet/Change Speed	- 2147483648	2147483 647	0	ie	1	0x3010 sub 0x04	INTEGER 32	R/W
							0x2208 – 0x2209		
PrfPP_Neg_Pos ChgSpd_5	E622 - 623 - 5 - Profile Position Targhet/Change Speed	- 2147483648	2147483 647	0	ie	1	0x3010 sub 0x05	INTEGER 32	R/W
							0x220A – 0x220B		
PrfPP_Neg_Pos ChgSpd_6	E624 - 625 - 6 - Negative Profile Position Targhet/Change Speed	- 2147483648	2147483 647	0	ie	1	0x3010 sub 0x06	INTEGER 32	R/W
							0x220C – 0x220D		
PrfPP_Neg_Pos ChgSpd_7	E626 - 627 - 7 - Negative Profile Position Targhet/Change Speed	- 2147483648	2147483 647	0	ie	1	0x3010 sub 0x07	INTEGER 32	R/W
							0x220E – 0x220F		
PrfPP_Neg_Pos ChgSpd_8	E628 - 629 - 8 - Negative Profile Position Targhet/Change Speed	- 2147483648	2147483 647	0	ie	1	0x3010 sub 0x08	INTEGER 32	R/W
							0x2210 – 0x2211		
PrfPP_Neg_Pos ChgSpd_9	E630 - 631 - 9 - Negative Profile Position Targhet/Change Speed	- 2147483648	2147483 647	0	ie	1	0x3010 sub 0x09	INTEGER 32	R/W
							0x2212 – 0x2213		
PrfPP_Neg_Spe ed_0	E634 - 635 - 0 - Profile Negative Speed	0	2147483 647	0	ie/s	1	0x3011 sub 0x00	INTEGER 32	R/W
							0x2216 – 0x2217		
PrfPP_Neg_Spe ed_1	E636 - 637 - 1 - Profile Negative Speed	0	2147483 647	0	ie/s	1	0x3011 sub 0x01	INTEGER 32	R/W
							0x2218 – 0x2219		
PrfPP_Neg_Spe ed_2	E638 - 639 - 2 - Profile Negative Speed	0	2147483 647	0	ie/s	1	0x3011 sub 0x02	INTEGER 32	R/W
							0x221A – 0x221B		
PrfPP_Neg_Spe ed_3	E640 - 641 - 3 – Profile Negative Speed	0	2147483 647	0	ie/s	1	0x3011 sub 0x03	INTEGER 32	R/W
							0x221C – 0x221D		
PrfPP_Neg_Spe ed_4	E642 - 643 - 4 - Profile Negative Speed	0	2147483 647	0	ie/s	1	0x3011 sub 0x04	INTEGER 32	R/W
							0x221E – 0x221F		
PrfPP_Neg_Spe ed_5	E644 - 645 - 5 - Profile Negative Speed	0	2147483 647	0	ie/s	1	0x3011 sub 0x05	INTEGER 32	R/W
							0x2220 – 0x2221		
PrfPP_Neg_Spe ed_6	E646 - 647 - 6 - Profile Negative Speed	0	2147483 647	0	ie/s	1	0x3011 sub 0x06	INTEGER 32	R/W
							0x2222 – 0x2223		



Name	Description	Min	Max	Default	UM	Scale	index	Type	Access
PrfPP_Neg_Speed_7	E648 - 649 - 7 - Profile Negative Speed	0	2147483 647	0	ie/s	1	0x3011 sub 0x07	INTEGER 32	R/W
							0x2224 – 0x2225		
PrfPP_Neg_Speed_8	E650 - 651 - 8 - Profile Negative Speed	0	2147483 647	0	ie/s	1	0x3011 sub 0x08	INTEGER 32	R/W
							0x2226 – 0x2227		
PrfPP_Neg_Speed_9	E652 - 653 - 9 - Profile Negative Speed	0	2147483 647	0	ie/s	1	0x3011 sub 0x09	INTEGER 32	R/W
							0x2228 – 0x2229		
PrfPP_Neg_Acc_Dec_0	E510 – 511 – Negative Profile Acc Dec 0	10223	2147483 647	5000 00	ie/s <sup>2</sup>	1	0x301A sub 0x00	INTEGER 32	R/W
							0x229a- 0x229b		
PrfPP_Neg_Acc_Dec_1	E512 – 513 – Negative Profile Acc Dec 1	10223	2147483 647	5000 00	ie/s <sup>2</sup>	1	0x301A sub 0x01	INTEGER 32	R/W
							0x229c – 0x229d		
PrfPP_Neg_Acc_Dec_2	E514 – 515 – Negative Profile Acc Dec 2	10223	2147483 647	5000 00	ie/s <sup>2</sup>	1	0x301A sub 0x02	INTEGER 32	R/W
							0x229e – 0x229f		
PrfPP_Neg_Acc_Dec_3	E516 – 517 – Negative Profile Acc Dec 3	10223	2147483 647	5000 00	ie/s <sup>2</sup>	1	0x301A sub 0x03	INTEGER 32	R/W
							0x22a0 – 0x22a1		
PrfPP_Neg_Acc_Dec_4	E518 – 519 – Negative Profile Acc Dec 4	10223	2147483 647	5000 00	ie/s <sup>2</sup>	1	0x301A sub 0x04	INTEGER 32	R/W
							0x22a2 – 0x22a3		
PrfPP_Neg_Acc_Dec_5	E520 – 521 – Negative Profile Acc Dec 5	10223	2147483 647	5000 00	ie/s <sup>2</sup>	1	0x301A sub 0x05	INTEGER 32	R/W
							0x22a4 – 0x22a5		
PrfPP_Neg_Acc_Dec_6	E522 – 523 – Negative Profile Acc Dec 6	10223	2147483 647	5000 00	ie/s <sup>2</sup>	1	0x301A sub 0x06	INTEGER 32	R/W
							0x22a6 – 0x22a7		
PrfPP_Neg_Acc_Dec_7	E524 – 525 – Negative Profile Acc Dec 7	10223	2147483 647	5000 00	ie/s <sup>2</sup>	1	0x301A sub 0x07	INTEGER 32	R/W
							0x22a8 – 0x22a9		
PrfPP_Neg_Acc_Dec_8	E526 – 527 – Negative Profile Acc Dec 8	10223	2147483 647	5000 00	ie/s <sup>2</sup>	1	0x301A sub 0x08	INTEGER 32	R/W
							0x22aa- 0x22ab		
PrfPP_Neg_Acc_Dec_9	E528 – 529 – Negative Profile Acc Dec 9	10223	2147483 647	5000 00	ie/s <sup>2</sup>	1	0x301A sub 0x09	INTEGER 32	R/W
							0x22ac – 0x22ad		
PrfPP_Neg_Final_Dec	E530 – 531 – Negative Profile Final Deceleration	10223	2147483 647	5000 00	ie/s <sup>2</sup>	1	0x301A sub 0x0a	INTEGER 32	R/W
							0x22ae – 0x22af		
PrfPP_Neg_NrPrfSpd	E656 - Negative Profile Nr. Change Speed	0	8	0			0x301C sub 0x01	INTEGER 8	R/W
							0x222C		
MAX_SPEED_I E	d72-73 – Speed Max [ie] (P65 – MOT_MAX_SPEED)						0x200F sub 0x48	INTEGER32	R
							0x03C8 – 0x03C9		

Name	Description	Min	Max	Default	UM	Scale	index	Type	Access
PrfPP_Neg_Ind TrgPos	E657 - Index of Negative Profile Position Target	0	9	9		1	0x301C sub 0x00	INTEGER 8	R/W
							0x222D		

Tab. 14- Multi-profile Negative Speed parameters and Objects

### 2.6.2.1 Torque negative profile

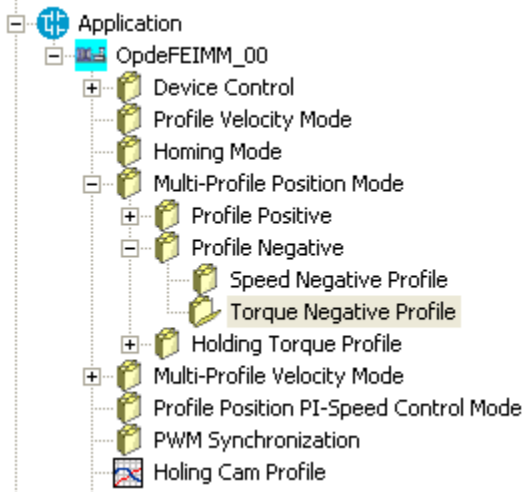

Name	Description	Min	Max	Default	UM	Scale	index	Type	Access
PrfPP_Neg_Pos ChgTrq_0	E658 - 659 - 0 - Profile Negative Position Change Torque	-	2147483648	2147483647	0	ie	0x3013 sub 0x00	INTEGER 32	R/W
							MODBUS: 0x222E – 0x222F		
PrfPP_Neg_Pos ChgTrq_1	E660 - 661 - 1 - Profile Negative Position Change Torque	-	2147483648	2147483647	0	ie	0x3013 sub 0x01	INTEGER 32	R/W
							0x2230 – 0x2231		
PrfPP_Neg_Pos ChgTrq_2	E662 - 663 - 2 - Profile Negative Position Change Torque	-	2147483648	2147483647	0	ie	0x3013 sub 0x02	INTEGER 32	R/W
							0x2232 – 0x2233		
PrfPP_Neg_Pos ChgTrq_3	E664 - 665 - 3 - Profile Negative Position Change Torque	-	2147483648	2147483647	0	ie	0x3013 sub 0x03	INTEGER 32	R/W
							0x2234 – 0x2235		
PrfPP_Neg_Pos ChgTrq_4	E666 - 667 - 4 - Profile Negative Position Change Torque	-	2147483648	2147483647	0	ie	0x3013 sub 0x04	INTEGER 32	R/W
							0x2236 – 0x2237		
PrfPP_Neg_Pos ChgTrq_5	E668 - 669 - 5 - Profile Negative Position Change Torque	-	2147483648	2147483647	0	ie	0x3013 sub 0x05	INTEGER 32	R/W
							0x2238 – 0x2239		
PrfPP_Neg_Pos ChgTrq_6	E670 - 671 - 6 - Profile Negative Position Change	-	2147483648	2147483647	0	ie	0x3013 sub 0x06	INTEGER 32	R/W

Name	Description	Min	Max	Default	UM	Scale	index	Type	Access
	Torque						0x223A – 0x223B		
PrfPP_Neg_Pos ChgTrq_7	E672 - 673 - 7 - Profile Negative Position Change Torque	- 2147483648	2147483647	0	ie	1	0x3013 sub 0x07 0x223C – 0x223D	INTEGER 32	R/W
PrfPP_Neg_Pos ChgTrq_8	E674 - 675 - 8 - Profile Positive Position Change Torque	- 2147483648	2147483647	0	ie	1	0x3013 sub 0x08 0x223E – 0x223F	INTEGER 32	R/W
PrfPP_Neg_Torque_0	E681 - 0 - Profile Negative Limit Torque	0.00	400.00	0.00	% MOT_T_NOM	100	0x3014 sub 0x00 0x2245	UNSIGNED 16	R/W
PrfPP_Neg_Torque_1	E682 - 1 - Profile Negative Limit Torque	0.00	400.00	0.00	% MOT_T_NOM	100	0x3014 sub 0x01 0x2246	UNSIGNED 16	R/W
PrfPP_Neg_Torque_2	E683 - 2 - Profile Negative Limit Torque	0.00	400.00	0.00	% MOT_T_NOM	100	0x3014 sub 0x02 0x2247	UNSIGNED 16	R/W
PrfPP_Neg_Torque_3	E684 - 3 - Profile Negative Limit Torque	0.00	400.00	0.00	% MOT_T_NOM	100	0x3014 sub 0x03 0x2248	UNSIGNED 16	R/W
PrfPP_Neg_Torque_4	E685 - 4 - Profile Negative Limit Torque	0.00	400.00	0.00	% MOT_T_NOM	100	0x3014 sub 0x04 0x2249	UNSIGNED 16	R/W
PrfPP_Neg_Torque_5	E686 - 5 - Profile Negative Limit Torque	0.00	400.00	0.00	% MOT_T_NOM	100	0x3014 sub 0x05 0x224A	UNSIGNED 16	R/W
PrfPP_Neg_Torque_6	E687 - 6 – Profile Negative Limit Torque	0.00	400.00	0.00	% MOT_T_NOM	100	0x3014 sub 0x06 0x224B	UNSIGNED 16	R/W
PrfPP_Neg_Torque_7	E688 - 7 - Profile Negative Limit Torque	0.00	400.00	0.00	% MOT_T_NOM	100	0x3014 sub 0x07 0x224C	UNSIGNED 16	R/W
PrfPP_Neg_Torque_8	E689 - 8 - Profile Negative Limit Torque	0.00	400.00	0.00	% MOT_T_NOM	100	0x3014 sub 0x08 0x224D	UNSIGNED 16	R/W
PrfPP_Neg_Torque_9	E690- 9 - Profile Negative Limit Torque	0.00	400.00	0.00	% MOT_T_NOM	100	0x3014 sub 0x09 0x224E	UNSIGNED 16	R/W
PrfPP_Neg_NrPrfTrq	E703 - Negative Profile Nr. Change Limit Torque	0	8	0		1	0x301C sub 0x02 0x225B	INTEGER 8	R/W

**Tab. 15- Torque Negative Profile parameters and Objects**

Example: **Multi-profile Negative.**

Parameters:

**pPOS\_FRAC** = 16 bit (1 turn = 65536 ie),  
**PrfPP\_Neg\_NrPrfSpd** = 2,  
**PrfPP\_Neg\_IndTrgPos** =9,  
**PrfPP\_Neg\_NrPrfTrq** = 2.  
**pTRQ\_POS\_RAMPS** = 20.0 ms

PrfPP_Neg_PosChgSpd_7 = 638966 ie	PrfPP_Neg_Speed_7 = 589815 ie/s
PrfPP_Neg_PosChgSpd_8 = 393210 ie	PrfPP_Neg_Speed_8 = 983020 ie/s
PrfPP_Neg_PosChgSpd_9 (TARGET) = -196605 ie	PrfPP_Neg_Speed_9 = 589810 ie/s
.....	.....
PrfPP_Neg_Acc_Dec_7 = 3932100 ie/s <sup>2</sup>	
PrfPP_Neg_Acc_Dec_8 = 2949075 ie/s <sup>2</sup>	
PrfPP_Neg_Acc_Dec_8 = 1966050 ie/s <sup>2</sup>	
PrfPP_Neg_Final_Dec = 9830250 ie/s <sup>2</sup>	

PrfPP_Neg_PosChgTrq_7 = 2097152 ie	PrfPP_Neg_Torque_7 = 141.75 %
PrfPP_Neg_PosChgTrq_8 = 4194304 ie	PrfPP_Neg_Torque_8 = 96.43 %
PrfPP_Neg_PosChgTrq_9 = 6291456 ie	PrfPP_Neg_Torque_9 = 48.21 %

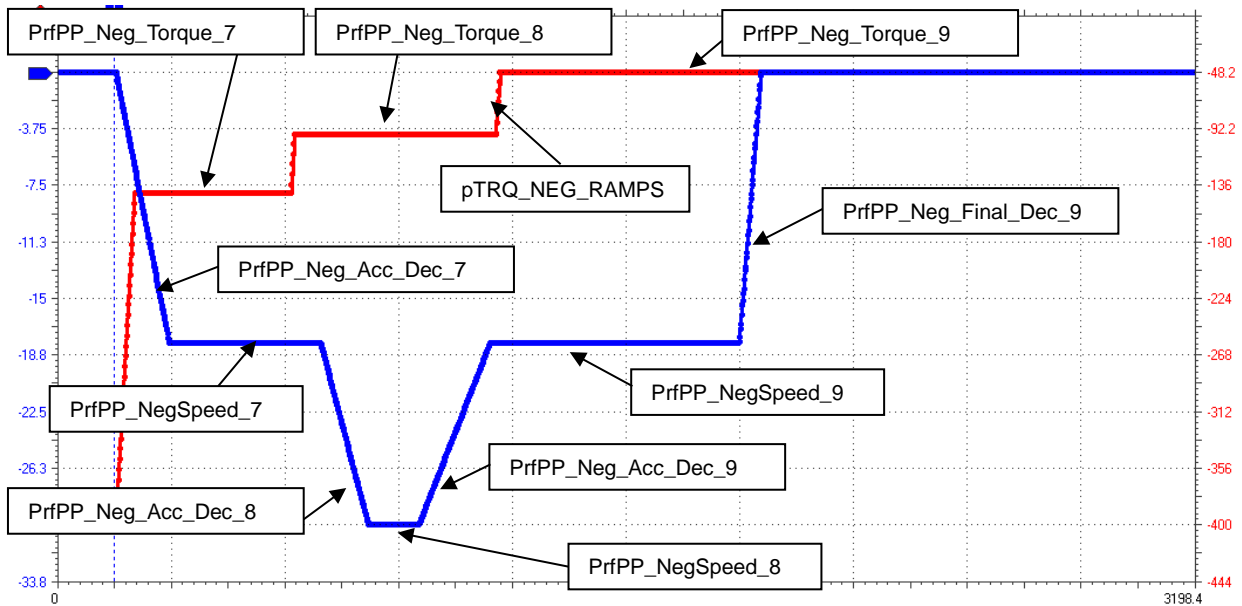

Fig. 11- Multi-profile Negative Example

### 2.6.2.2 Software limits (Safe stop zone)

In Multi-Profile position zone, the actual position is checked in order to don't exceed the safe stop zone. Parameters **E40-41 – pSWLIMITMIN** and **E42-43 pSWLIMITMAX** define the safe stop zone. If the negative profile is enabled and actual position is less than **pSWLIMITMIN** or if profile positive is enabled and actual position is greater than **pSWLIMITMAX** a deceleration ramp of **E08-09 – pQSEDEC** is enabled and the motor is stopped at zero speed.

If these limits are applied in Injection axis, the system can Interrupt the Holding Profile (if enabled) and apply directly the quick stop ramp.

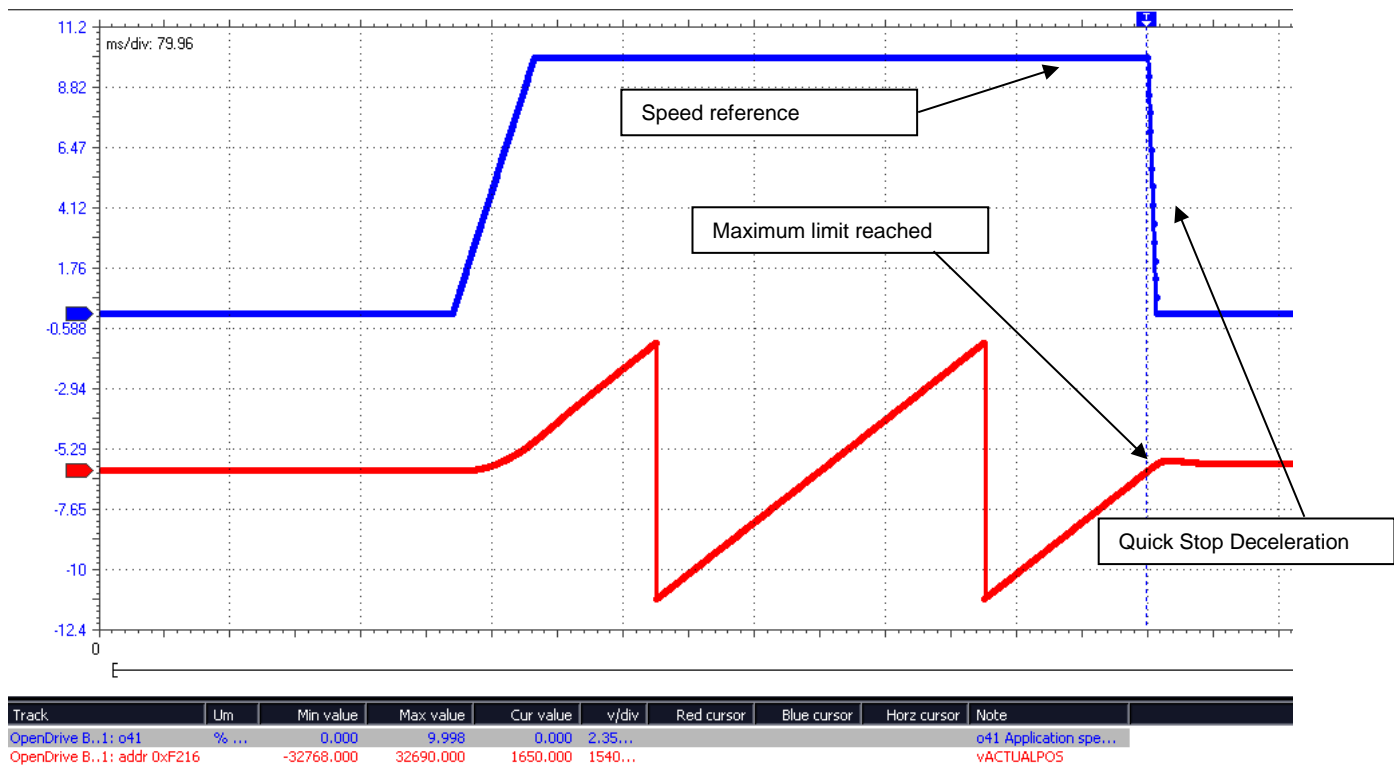
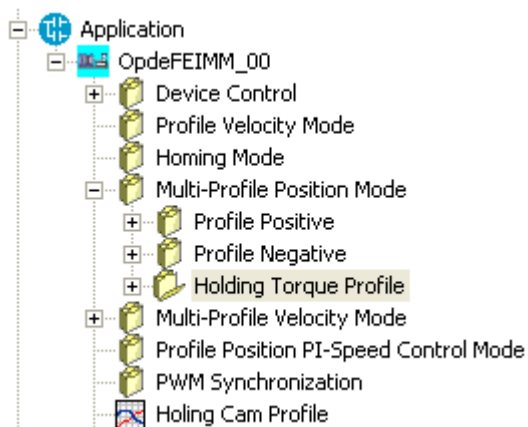

Fig. 12- Software limits

### 2.6.3 HOLDING TORQUE PROFILE



Holding Torque Profile is enabled at the end or during the Multi-Profile Position Negative, which control the Injection axes.

User can chose in the HMI up to ten points, start point, interpolation type and much more.

Name	Description	Min	Max	Default	UM	Scale	index	Type	Access
PrfPP_StartTrqCam	E716 - Profile Negative Initial Torque Holding Cam Profile	0.00	400.00	0.00	% MOT_T_NOM	100	CAN: 0x3018 sub 0x00 MODBUS: 0x2268	UNSIGNED 16	R/W

Name	Description	Min	Max	Default	UM	Scale	index	Type	Access
PrfPP_EndTrqRef_0	E717 - 0 - Profile Negative End Limit Torque	0.00	400.00	0.00	% MOT_T_NOM	100	0x3018 sub 0x01	UNSIGNED D 16	R/W
							0x2269		
PrfPP_EndTrqRef_1	E718 - 1 - Profile Negative End Limit Torque	0.00	400.00	0.00	% MOT_T_NOM	100	0x3018 sub 0x02	UNSIGNED D 16	R/W
							0x226A		
PrfPP_EndTrqRef_2	E719 - 2 - Profile Negative End Limit Torque	0.00	400.00	0.00	% MOT_T_NOM	100	0x3018 sub 0x03	UNSIGNED D 16	R/W
							0x226B		
PrfPP_EndTrqRef_3	E720 - 3 - Profile Negative End Limit Torque	0.00	400.00	0.00	% MOT_T_NOM	100	0x3018 sub 0x04	UNSIGNED D 16	R/W
							0x226C		
PrfPP_EndTrqRef_4	E721 - 4 - Profile Negative End Limit Torque	0.00	400.00	0.00	% MOT_T_NOM	100	0x3018 sub 0x05	UNSIGNED D 16	R/W
							0x226D		
PrfPP_EndTrqRef_5	E722 - 5 - Profile Negative End Limit Torque	0.00	400.00	0.00	% MOT_T_NOM	100	0x3018 sub 0x06	UNSIGNED D 16	R/W
							0x226E		
PrfPP_EndTrqRef_6	E723 - 6 - Profile Negative End Limit Torque	0.00	400.00	0.00	% MOT_T_NOM	100	0x3018 sub 0x07	UNSIGNED D 16	R/W
							0x226F		
PrfPP_EndTrqRef_7	E724 - 7 - Profile Negative End Limit Torque	0.00	400.00	0.00	% MOT_T_NOM	100	0x3018 sub 0x08	UNSIGNED D 16	R/W
							0x2270		
PrfPP_EndTrqRef_8	E725 - 8 - Profile Negative End Limit Torque	0.00	400.00	0.00	% MOT_T_NOM	100	0x3018 sub 0x09	UNSIGNED D 16	R/W
							0x2271		
PrfPP_EndTrqRef_9	E726 - 9 - Profile Negative End Limit Torque	0.00	400.00	0.00	% MOT_T_NOM	100	0x3018 sub 0x0A	UNSIGNED D 16	R/W
							0x2272		
PrfPP_TimeEndTrq_0	E736 - Profile Negative -Set Time of End Limit Torque 0	0	65535	0	ms	1	0x3019 sub 0x00	UNSIGNED D 16	R/W
							0x227C		
PrfPP_TimeEndTrq_1	E737 - Profile Negative -Set Time of End Limit Torque 0	0	65535	0	ms	1	0x3019 sub 0x01	UNSIGNED D 16	R/W
							0x227D		
PrfPP_TimeEndTrq_2	E738 - Profile Negative -Set Time of End Limit Torque 0	0	65535	0	ms	1	0x3019 sub 0x02	UNSIGNED D 16	R/W
							0x227E		
PrfPP_TimeEndTrq_3	E739 - Profile Negative -Set Time of End Limit Torque 0	0	65535	0	ms	1	0x3019 sub 0x03	UNSIGNED D 16	R/W
							0x227F		
PrfPP_TimeEndTrq_4	E740 - Profile Negative -Set Time of End Limit Torque 0	0	65535	0	ms	1	0x3019 sub 0x04	UNSIGNED D 16	R/W
							0x2280		
PrfPP_TimeEndTrq_5	E741 - Profile Negative -Set Time of End Limit Torque 0	0	65535	0	ms	1	0x3019 sub 0x05	UNSIGNED D 16	R/W
							0x2281		
PrfPP_TimeEndTrq_6	E742 - Profile Negative -Set Time of End Limit Torque 0	0	65535	0	ms	1	0x3019 sub 0x06	UNSIGNED D 16	R/W
							0x2282		
PrfPP_TimeEndTrq_7	E743 - Profile Negative -Set Time of End Limit Torque 0	0	65535	0	ms	1	0x3019 sub 0x07	UNSIGNED D 16	R/W
							0x2283		
PrfPP_TimeEndTrq_8	E744 - Profile Negative -Set Time of End Limit Torque 0	0	65535	0	ms	1	0x3019 sub 0x08	UNSIGNED D 16	R/W
							0x2284		
PrfPP_TimeEndTrq_9	E745 - Profile Negative -Set Time of End Limit Torque 0	0	65535	0	ms	1	0x3019 sub 0x09	UNSIGNED D 16	R/W

Name	Description	Min	Max	Default	UM	Scale	index	Type	Access
							0x2285		
PrfPP_NrPrfEndTrq	E748 - Nr of Profile Negative Limit Torque	0	10	0		1	0x301C sub 0x03	INTEGER 8	R/W
							0x2288		
PrfPP_SelType_HoldCam	E750 – Profile Holding Cam Profile Interpolation Type	Range		0		1	0x301C sub 0x05	INTEGER 8	R/W
		0	0-Linear						
		1	1-S-Ramps						
		2	2-Cubic Spline						
							0x228A		
PrfPP_SRamps_HoldCamTime	E751 - Profile S-Ramps Time Holding Cam Profile	0	30000	0	ms	1	0x3019 sub 0x0A	UNSIGNED 16	R/W
							0x228B		
PrfPP_Acc_HoldCam	E788-789 – Profile Holding Cam Acceleration	10223	2147483647	500000	ie/s <sup>2</sup>		0x301a sub 0x0b	UNSIGNED 32	R/W
							0x22b1 – 0x22b2		
PrfPP_Dec_HoldCam	E790-791 – Profile Holding Cam Deceleration	10223	2147483647	500000	ie/s <sup>2</sup>		0x301a sub 0x0c	UNSIGNED 32	R/W
							0x22b3 – 0x22b4		
PrfPP_TrqLim_StartHoldCam	E691 - Profile Negative Torque Limit Start Holding Cam Profile	0.00	400.00	0.00	% MOT_T_NOM	100	0x3014 sub 0x0a	UNSIGNED 16	R/W
							0x224f		
PrfPP_Neg_Sel_EndTrq	E749 – Profile Negative – Type switch mode	Range		0		1	0x301C sub 0x04	UNSIGNED 8	R/W
		0	0 - None						
		1	1 – Target Reach Locking						
		2	2 – Target Reach Start Holding Cam Profile						
		3	3 – Pos start Holding Cam Profile						
		4	4 –Pos and trq start Holding Cam Profile						
		5	5 – Pos and AI start Holding Cam Profile						
		6	6 – Pos and DI start Holding Cam Profile						
7	7 – Pos and time start Holding Cam Profile								
PrfPP_Neg_Trq_Lim_Start_HoldCam	E691 – Profile Negative Torque Limit Start Holding Cam Profile	0.00	400.00	0.00	% MOT_T_NOM	40.96	0x3014 sub 0x0a	INTEGER 16	R/W
							0x224f		
PrfPP_SelAI_StartHoldCam	E752 - Profile Neg. AI Selection Start Holding Cam Profile	Range		0		1	0x301C sub 0x06	INTEGER 8	R/W
		0	0 – Analog input 1						
		1	1 – Analog input 2						
		2	2 – Analog input 3						
							0x228C		
PrfPP_Time_StartHoldCam	E753 - PrfPP_Neg_Time_StartHoldCam	0	30000	0	ms	1	0x3019 sub 0x0B	UNSIGNED 16	R/W
							0x228D		
PrfPP_AILim_StartHoldCam	E754 - Profile Negative AI Limit Start Holding Cam Profile	0.00	400.00	0.00	%	100	0x3018 sub 0x0B	UNSIGNED 16	R/W
							0x228E		
PrfPPNeg_PosLimit	E676 – 677 – Profile Negative Position Start Cam Profile	-2147483648	2147483647	0	ie				
pSWLIMITMIN	E40 – 41 – Min Position Limit	-	2147483	0	ie	1	0x3102	INTEGER	R/W

Name	Description	Min	Max	Default	UM	Scale	index	Type	Access
		2147483647	648				sub 0x20	32	
							0x0154 – 0x0155		
pSWLIMITMAX	E42 – 43 – Max Position Limit	- 2147483647	2147483648	0	ie	1	0x3102 sub 0x22	INTEGER 32	R/W
							0x0156 – 0x0157		
MAX_POS_HOLD_CAM	E208 – 209 – Maximum position in Holding Cam Profile					1	0x3100 sub 0x04	INTEGER 32	R
							0x2072 – 0x2073		
MIN_POS_HOLD_CAM	E210 – 211 – Minimum position in Holding Cam Profile					1	0x3100 sub 0x05	INTEGER 32	R
							0x2074 – 0x2075		

**Tab. 16- Holding Negative Profile parameters and Objects**

Example 2: Holding End Cam profile.

Suppose to enable the End Holding Cam profile at the end of Multi-profile position.

PrfPP\_Pos\_NrPrfEndTrq = 11,

**Tab. 16** shows the End Holding Positive Cam Profile for this example.

PrfPP_Pos_StartTrqCam = 40.00%	
PrfPP_Pos_EndTrqRef_0 = 10.00%	PrfPP_Pos_TimeEndTrq_0 = 80 ms
PrfPP_Pos_EndTrqRef_1 = 10.00%	PrfPP_Pos_TimeEndTrq_1 = 400 ms
PrfPP_Pos_EndTrqRef_2 = 77.14%	PrfPP_Pos_TimeEndTrq_2 = 80 ms
PrfPP_Pos_EndTrqRef_3 = 77.14%	PrfPP_Pos_TimeEndTrq_3 = 400 ms
PrfPP_Pos_EndTrqRef_4 = 38.57%	PrfPP_Pos_TimeEndTrq_4 = 80 ms
PrfPP_Pos_EndTrqRef_5 = 38.57%	PrfPP_Pos_TimeEndTrq_5 = 400 ms
PrfPP_Pos_EndTrqRef_6 = 77.14%	PrfPP_Pos_TimeEndTrq_6 = 80 ms
PrfPP_Pos_EndTrqRef_7 = 77.14%	PrfPP_Pos_TimeEndTrq_7 = 400 ms
PrfPP_Pos_EndTrqRef_8 = 19.28%	PrfPP_Pos_TimeEndTrq_8 = 80 ms
PrfPP_Pos_EndTrqRef_9 = 19.28%	PrfPP_Pos_TimeEndTrq_9 = 100 ms

**Tab. 17- End Holding Positive Cam Profile**

Next picture shows the result: at the end of Multi-Profile Position, the End Holding Cam-profile is enabled. The red signal is the Injection Holding Cam Profile (seen in the drive in torque reference). After the Injection cycle (if closed loop is enabled) is possible to read the feed-back signal captured from the load cell.



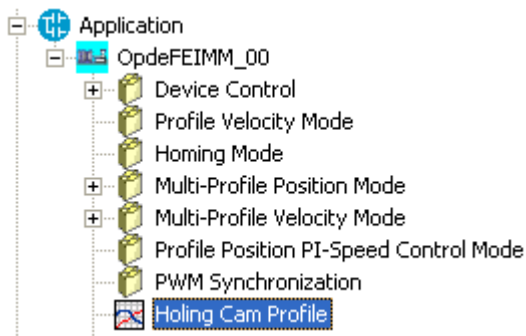

Graph shows directly the Holding Cam Profile set-point.

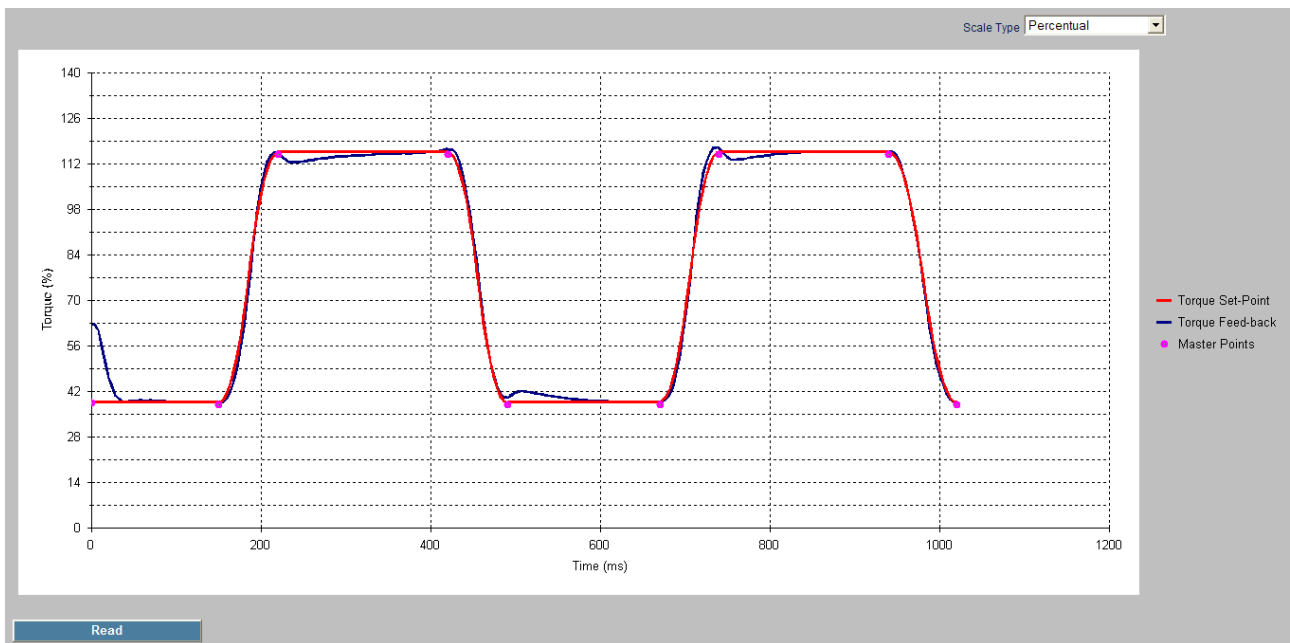

**Fig. 13- Holding End Cam profile Graph example**

If one of the points or interpolation type are changed all the Cam points are re-calculate. Is possible to refresh the graph with “Read” button.

Internal Cam point are available in with some Modbus address starting from 0x2384 (9092). There are three arrays of 257 values **X[0...256]** and **Y[0...256]** and **Y'[0...256]** where the user can read the reference points and the feed-back

Name	Type	Modbus Address
X[0]	UNSIGNED 16	0x2384 (9092)
Y[0]	INTEGER 16	0x2385 (9093)
Y'[0]	INTEGER 16	0x2386 (9094)
X[1]	UNSIGNED 16	0x2387 (9095)
Y[1]	INTEGER16	0x2388 (9096)
Y'[1]	INTEGER16	0x2388 (9097)
.....		
X[256]	UNSIGNED 16	0x2684 (9860)
Y[256]	INTEGER 16	0x2685 (9861)
Y'[256]	INTEGER 16	0x2686 (9862)

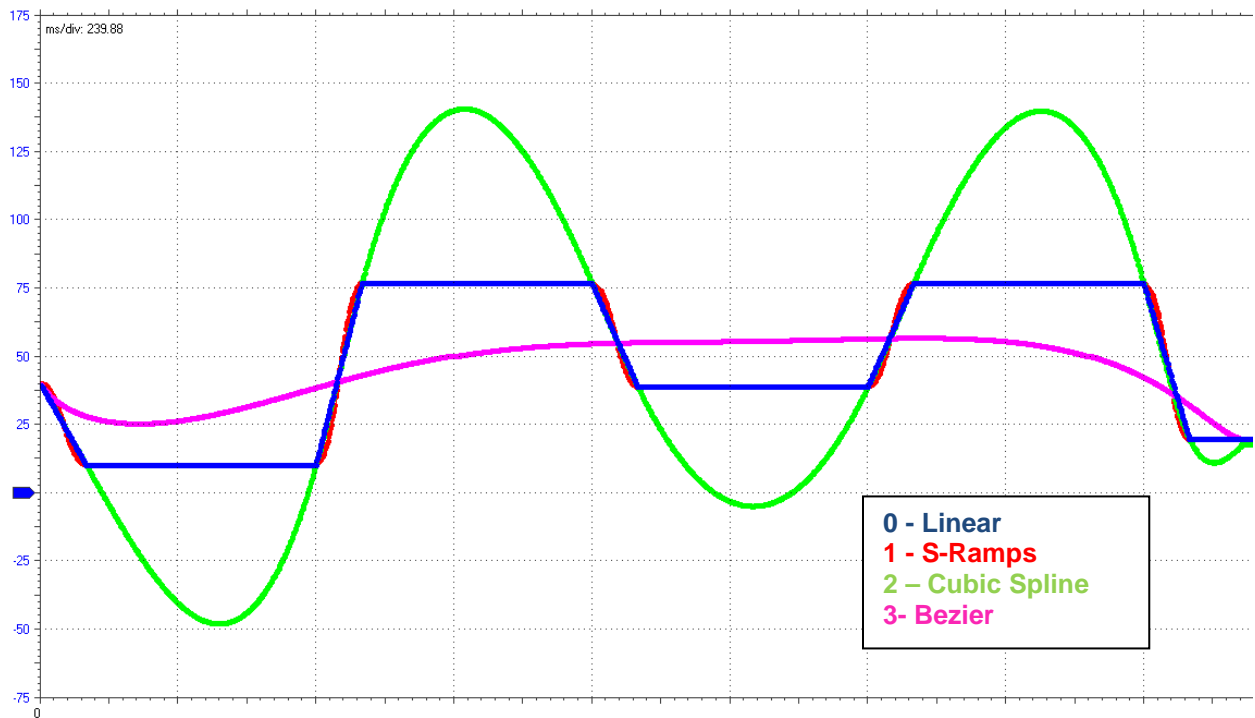

Fig. 14- Holding End Cam profile Interpolation Type

### 2.6.3.0 Step Line

Is possible also to enable e step linear interpolation setting the parameter **E750 – PrfPP\_SelType\_HoldCam = 4 – Step Linear**. In this way the points are used to create the steps for Injection Reference. The start point is not used in this modality.

**Example of 4 step:**

E716 – PrfPP_StartTrqCam = 10% (doesn't care)	/
E717 – PrfPP_EndTrqRef_0 = 20%	E736 – PrfPP_TimeEndTrq_0 = 100 ms
E718 – PrfPP_EndTrqRef_1 = 30%	E737 – PrfPP_TimeEndTrq_1 = 200 ms
E719 – PrfPP_EndTrqRef_2 = 40%	E738 – PrfPP_TimeEndTrq_2 = 50 ms
E720 – PrfPP_EndTrqRef_3 = 25%	E739 – PrfPP_TimeEndTrq_3 = 300 ms
.....	
E748 – PrfPP_NrPrfEndTrq = 4	

Tab. 18- Step Line Example

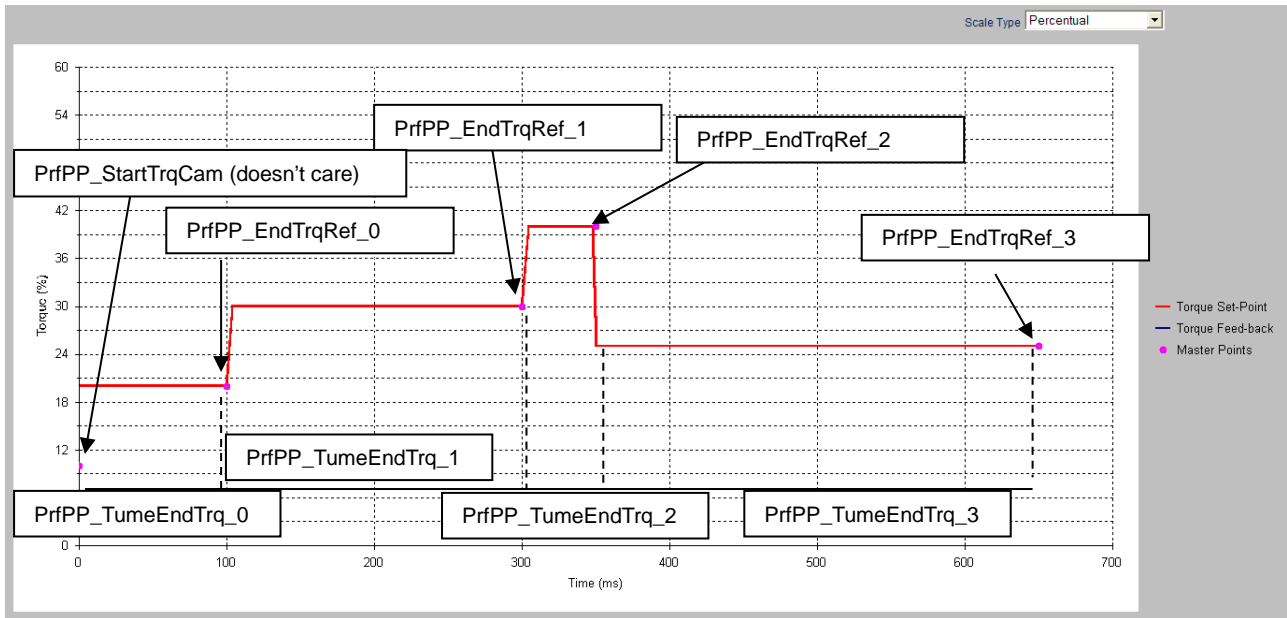

Fig. 15- Step Line Interpolation

### 2.6.3.1 Switch Holding Type

There are many ways to enable or not the Holding Positive Cam-profile. Parameters **PrfPP\_Pos\_Sel\_End\_Trq** show the options:

#### 0- None,

Multi profile position ends without End Holding Cam profile.

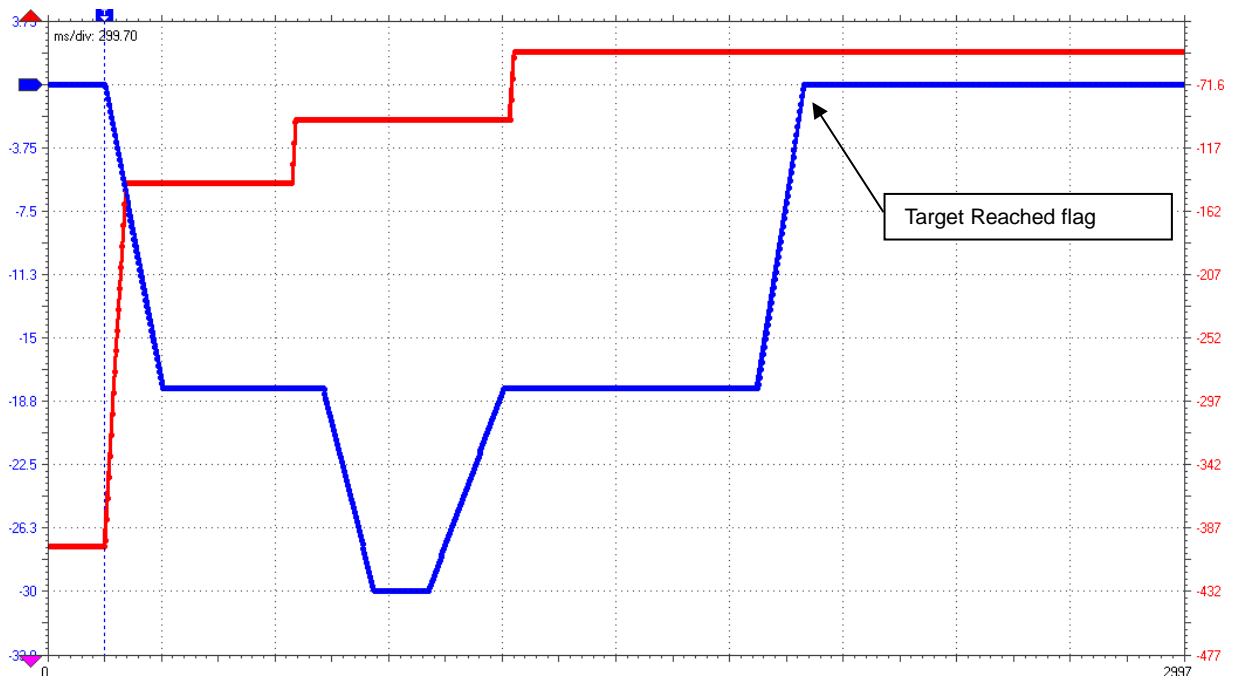

Fig. 16- None

## 1-Target reached locking

Multi profile position ends without End Holding Cam profile. When positioning ends (internal flag **Target reached** is enabled) a final speed reference of **PrfPP\_Pos\_EndSpdRef** is applied until the start positive profile command is enabled, and the positive torque limit is set to **PrfPP\_Pos\_StartTrqCam**.

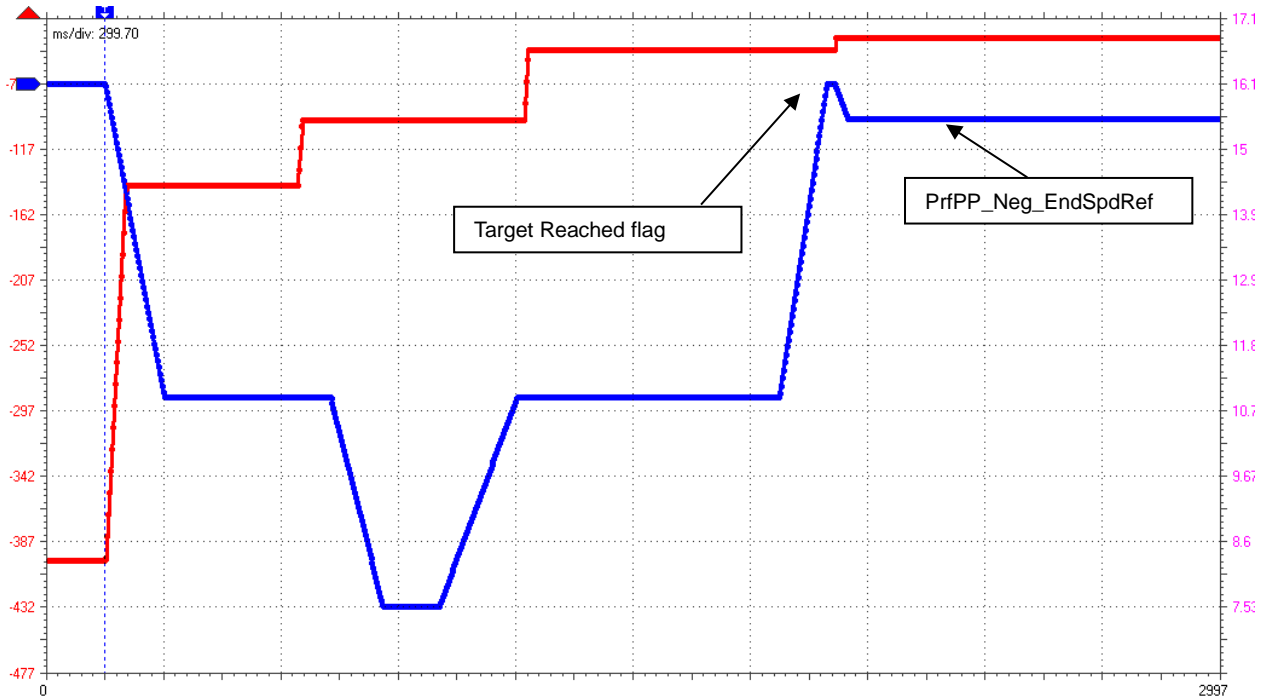

Fig. 17- Target reach locking

## 2-Target reached start Holding Cam Profile

When Multi-Profile position mode ends (**Target Reached** is enabled), Holding Cam Profile start. Torque positive and negative are opened and, if Closed Loop is not enabled, only a Derivative Feed-Forward is applied as speed reference.

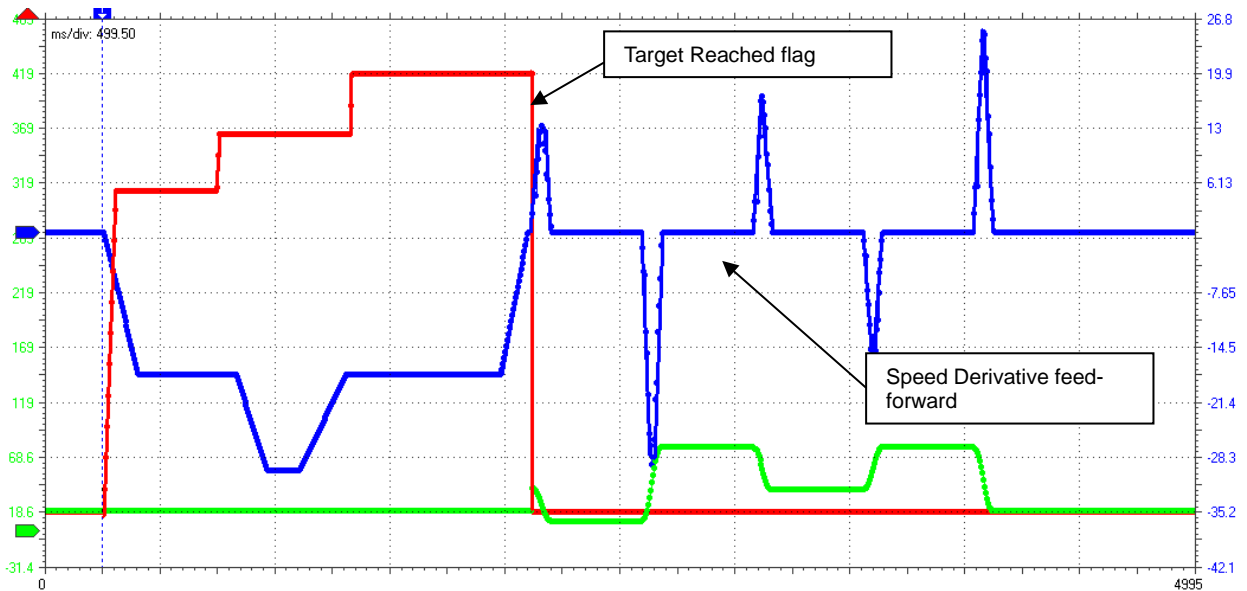

Fig. 18- Target reached Start Holding Cam

### 3-Position start Holding Cam Profile

When position reaches the value of **PrfPP\_Neg\_PosLimit** the Holding Cam Profile is automatically enabled without ending the positioning. If the multi-profile position end without reach the position **PrfPP\_Neg\_PosLimit**, the device does not enable the Holding Cam Profile.

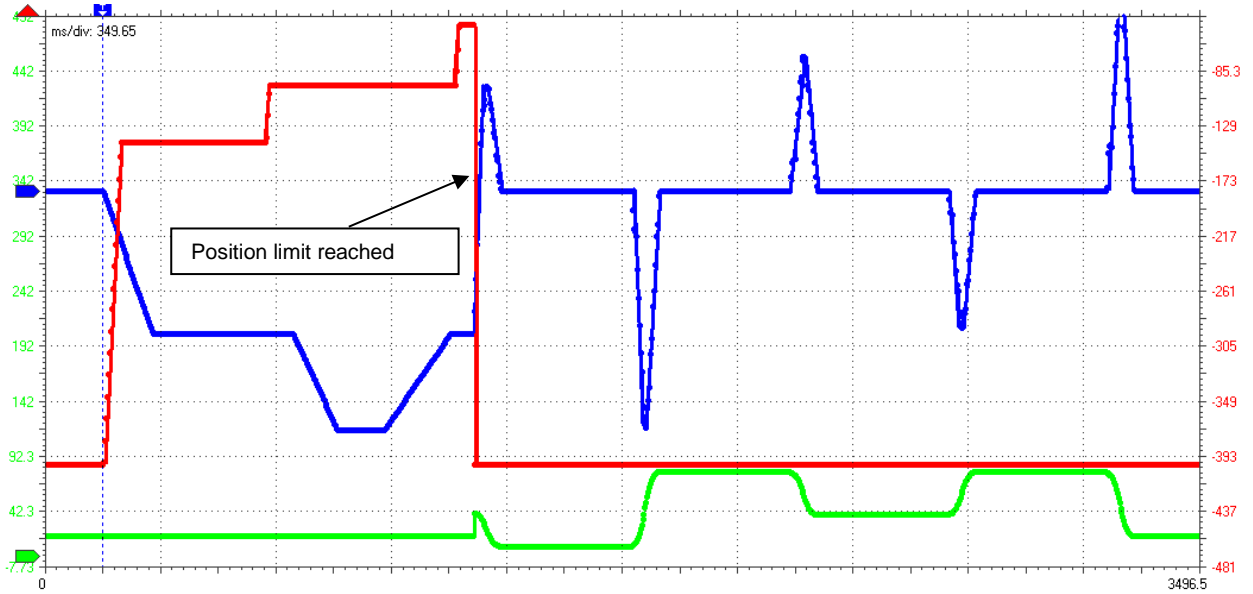

Fig. 19- Position Limit Start holding Cam

When Holding Cam Profile is enabled, speed reference is ramped with a parameter selectable in **PrfPP\_AccHoldCam** / **PrfPP\_DecHoldCam**. During all Injection Holding profile, speed references are ramped.

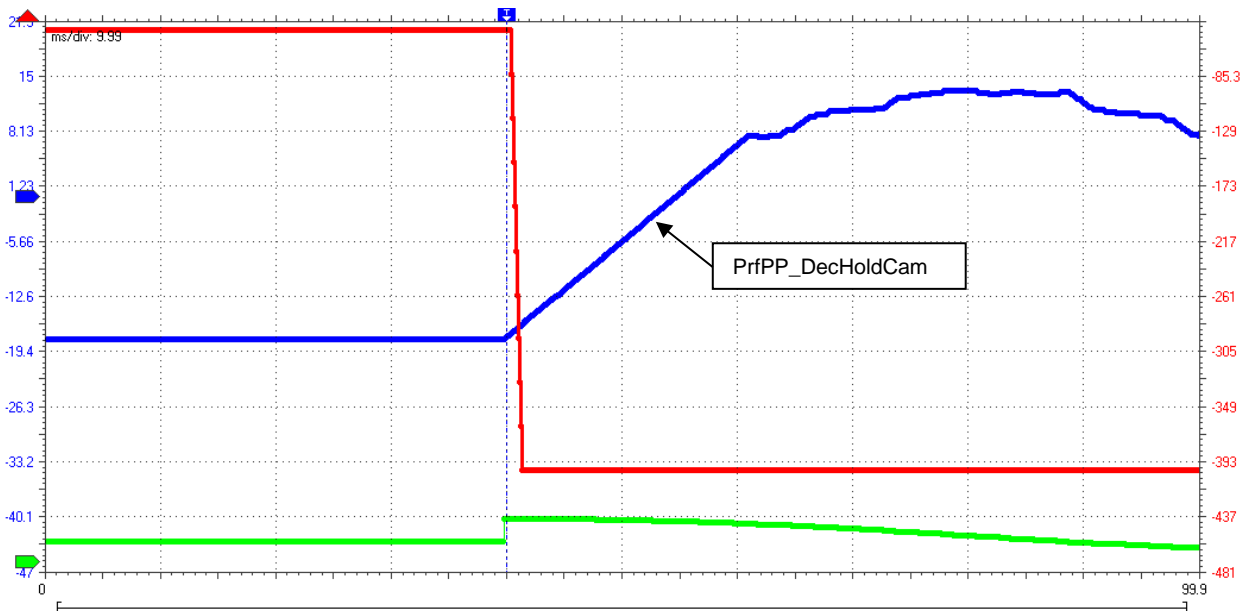

Fig. 20- Deceleration at the start of Holding Cam profile

#### 4-Position and Torque start Holding Cam Profile

This function is very similar to the previous, the device enables the Start Holding Cam Profile when position **PrfPP\_PosLimit** is reached and if the actual torque producer is greater than **PrfPP\_Pos\_TrqLim\_StartHoldCam**.

#### 5- Time start Holding Cam Profile

This function is very similar to mode 3 but the device enables the Start Holding Cam Profile when time set in **PrfPP\_Time\_StartHoldCam** is reached. The timer is enabled at start of Profile Negative.

#### 6- Digital Input 7 start Holding Cam Profile

This function is very similar to mode 3 but the device enable the Start Holding Cam Profile when logical input 7 is enabled.

### 2.6.3.2 Manufacturer specific bits

When Holding Cam Profile is enabled, **manufacturer specific bit 0** (bit 14 of status word) goes to high level. When Holding Cam Profile ends **manufacturer specific bit 1** (bit 15 of status word) is enabled.

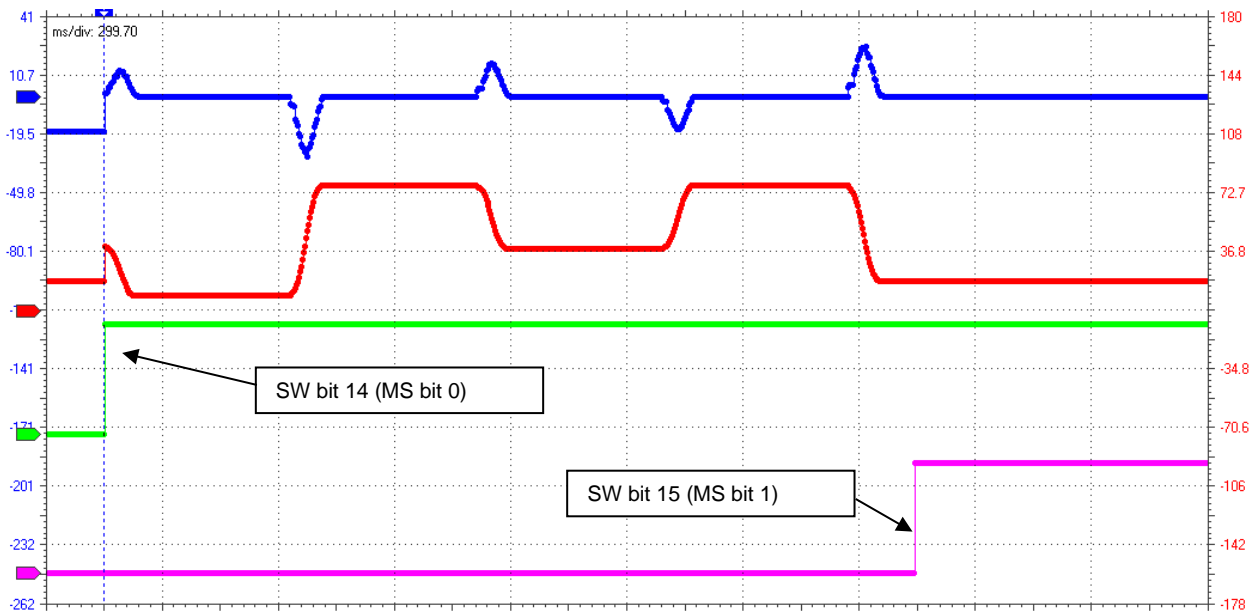

Fig. 21- STATUS WORD bit 14 and 15

When Holding Cam Profile is enabled, position loop is disabled but the actual position **D66-67 – ACTUALPOS** is checked continuously.

If the position becomes greater than **E42 – 43 – pSWLIMITMAX** or lower than **E40-41 pSWLIMITMIN**, the speed is automatically decelerated with ramp selectable in **E08 – 09 - pQSDEC**.

If Cam Profile is aborted, user will see only **manufacturer specific bit 0** will be at high level.

### 2.6.3.3 Torque closed loop

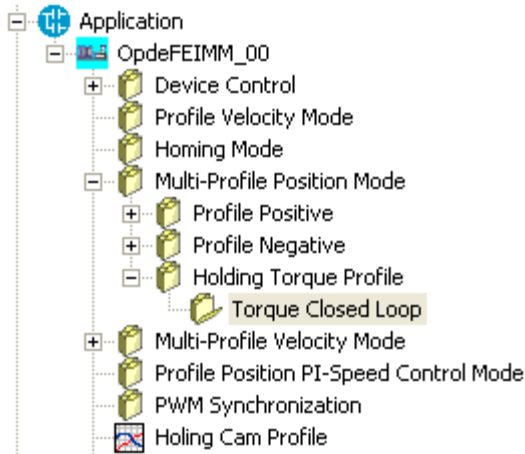

This function allows to close the torque closed loop on the Load Cell, connected directly with the Analog Input of OPDE. During the Injection-phase of the machine the set point-pressure is applied and a particular PI controller regulate the feed-back.

Name	Description	Min	Max	Default	UM	Scale	index	Type	Access
pEN_TRQ_LOOP	E65 – Enable close loop for negative holding cam profile	0	1	0			<b>CAN:</b> 0x3102 sub 0x20 (16 lsb)	INTEGER 32	R/W
							<b>MODBUS:</b> 0x016d		
PrfPP_Neg_Sel AI_StartHoldCam	E752 - Profile Neg. AI Selection Start Hoding Cam Profile	Range		0		1	0x301C sub 0x06	INTEGER 8	R/W
		0	0 – Analog input 1						
		1	1 – Analog input 2						
		2	2 – Analog input 3						
		3	3 – Analog input 16			0x228C			
PRESSURE_MAX	E755 - Maximum pressure				MPa		<b>MODBUS:</b> 0x228f	INTEGER 16	R
PRESSURE_NOM	E756 - Pressure at motor Nominal Torque				MPa		0x2290	INTEGER 16	R
PRESSURE_MAX_LCELL	E757 - Maximum full-scale Load Cell Pressure				MPa		0x2291	INTEGER 16	R
PrfPP_AccHoldCam	E788 – 789 – Profile Holding Cam Acceleration	10223	2147483 647	50000 0	ie/s <sup>2</sup>	1	<b>CAN:</b> 0x301a sub 0x0b	UNSIGNED D 16	R/W
							<b>MODBUS:</b> 0x22b0 – 0x22b1		
PrfPP_DecHoldCam	E790 – 791 – Profile Holding Cam Deceleration	10223	2147483 647	50000 0	ie/s <sup>2</sup>	1	0x301a sub 0x0b	UNSIGNED D 16	R/W
							0x22b2 – 0x22b3		
pTRQ_KP	E66 – KpV Torque PI proportional gain	300.00	-300.00	6.00			0x3102 sub 0x21 (16 lsb)	INTEGER 32	R/W
							0x016e		
pTRQ_TI	E67 – TIV Torque PI lead time constant	0.1	3000.0	30.0	ms	1	0x3102 sub 0x21	INTEGER 32	R/W

Name	Description	Min	Max	Default	UM	Scale	index	Type	Access
							(16 msb)		
							0x016f		
pTRQ_TF	E68 – TfV Profile Torque PI (filter) constant	0.0	25.0	0.4	ms		0x3102 sub 0x22 (16 lsb)	INTEGER 32	R/W
							0x0170		
pKP_PV_PI	E71 – Scaling Kp value of feedback PI	-300.00	300.00	0.00	%		0x3102 sub 0x23 (16 msb)	INTEGER 32	R/W
							0x0173		
pTD_PI	E72 – TD PI Derivative Time	0	19999	0	ms		0x3102 sub 0x24 (16 lsb)	INTEGER 32	R/W
							0x0174		
pTD_OUT_FLT	E73 – Derivative Output Filter	0.1	3000.0	2.0	ms		0x3102 sub 0x24 (16 msb)	INTEGER 32	R/W
							0x0175		
pENTRQFDW_CL_LOOP	E74 - Enable Torque FFW on closed loop	0	1				0x3102 sub 0x25 (16 lsb)	INTEGER 32	R/W
							0x0176		
pKP_TRQ_FFW	E75 – Scaling Kp value of torque FFW	0.00	300.00	0.00	%		0x3102 sub 0x25 (16 msb)	INTEGER 32	R/W
							0x0177		
pCLOSED_LOOP_P_BW	E77 – Closed Loop Bandwidth	0.1	100.0	25.0	Hz		0x3102 sub 0x26 (16 msb)	INTEGER 32	R/W
							0x0179		
pSP_PV_TF	E78 – SP – PV junction filter time constant	0.0	100.0	5.0	ms		0x3102 sub 0x27 (16 msb)	INTEGER 32	R/W
							0x017a		
ACT_SP_PID	D78 - Actual SP of Profile Vel. PI						0x200F sub 0x4E		
							0x03ce		
ACT_PV_PID	D79 - Actual PV Process Variable of Profile Vel. PI						0x200F sub 0x4F		
							0x03cf		
ACT_COM_P_PID	D80 – Actual P component of Profile PI				%		0x200F sub 0x50	INTEGER 16	R
							0x03d0		
ACT_COM_I_PID	D81 – Actual I component of Profile PI				%		0x200F sub 0x51	INTEGER 16	R
							0x03d1		
ACT_COM_ERR_PID	D82 – Actual Error SP-PV component of Profile PI				%		0x200F sub 0x52	INTEGER 16	R
							0x03d2		
ACT_OUT_PID	D83 – Actual Output of Profile PI				%		0x200F sub 0x52	INTEGER 16	R
							0x03d3		
START_SPEED_HOLD_CAM	E204 - 205 - Start speed in Holding Cam Profile				ie/s		0x3100 sub 0x0e	INTEGER 16	R
							0x2068-0x2069		
MAX_POS_HOLD_CAM	E206 - 207 - Maximum pos in Holding Cam Profile				ie		0x3100 sub 0x04	INTEGER 32	R





create a Speed Feed – Forward is sum to the PI Output.

When PI-controller is disabled the integral part it updated with the value of actual speed. In this case, when PI is enable, output (speed reference) starts from actual speed value and not from zero, in order to avoid speed inversions.

User can control the PI with these parameters: proportional gain **E66 – pTRQ\_KP**, integral time **E67 – pTRQ\_TI**, and filter **E68 – pTRQ\_TF**. PI Output with derivative feed-forward can be limit with parameter **E70 – pTRQ\_LMN\_MAX** and **E69 – pTRQ\_LMN\_MIN**.

User can also enable a Torque Feed-Forward with parameter **E65 – pENTRQ\_CL\_LOOP**. The effect of this feed-forward can be scaled with parameter **E75 – pKP\_TRQ\_FFW**.

**Fig. 23** shows an example of closed loop applied on a real FEIMM during an Injection-profile with polypropylene.

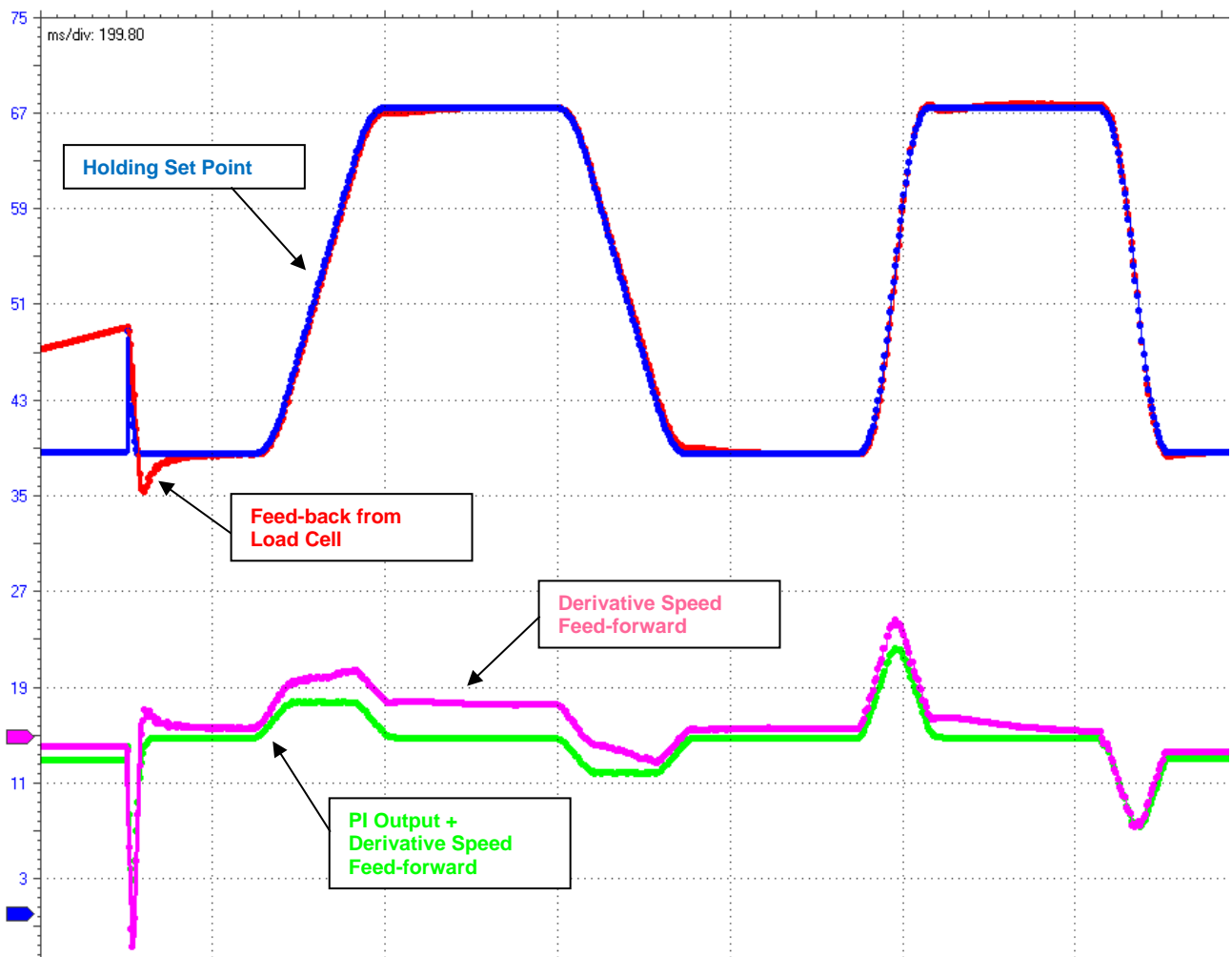

**Fig. 23-** Exemple of Injection Profile with torque closed loop enabled

If a Step – set point pressure is given, at the start of Holding Cam Profile, the SP is automatically filtered with start point equal to start PV and filter time constant (second order's filter) selectable in **E78 – pSP\_PV\_TF**. **Fig. 24** shows the result.

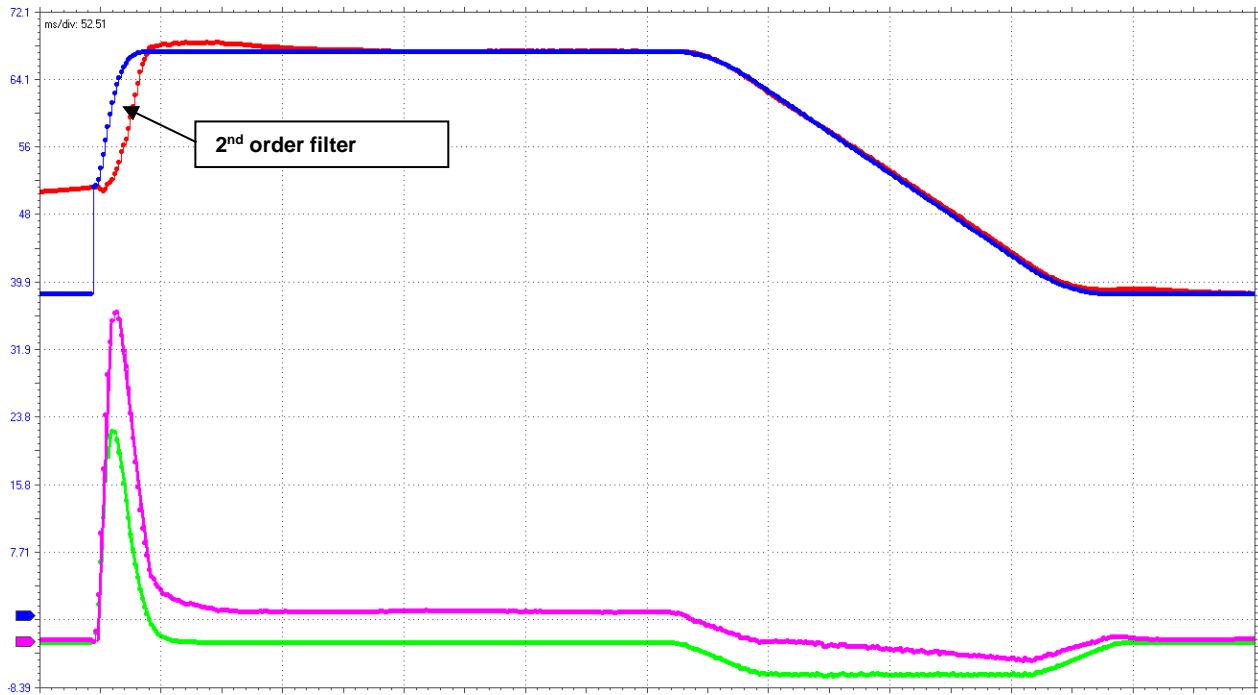

**Fig. 24- Exemple of Injection Profile with start Step pressure reference**

### 2.6.3.3.0 Scaling of pressure and torque

There are some parameters which represent the scaling pressure-torque for the Injection Moulding Machine size.

- E755 – PRESSURE\_MAX** is the maximum pressure of the machine,
- E756 – PRESSURE\_NOM** is the pressure at nominal torque of the motor,
- E757 – PRESSURE\_MAX\_LCELL** is the full-scale pressure of load cell (at 10V).

Example for 170 Ton Injection Multi Machine:

- **E755 – PRESSURE\_MAX** = 147,2 MPa,
- **E756- PRESSURE\_NOM** = 103,07 Mpa,
- **E757 – PRESSURE\_MAX\_LCELL** = 176,05 MPa.

The scaling of analogue input must be calculated **E71 – pKP\_PV\_PI = PRESSURE\_MAX\_LCELL / PRESSURE\_NOM = 169,77%**.

## 2.7 MULTI-PROFILE VELOCITY MODE

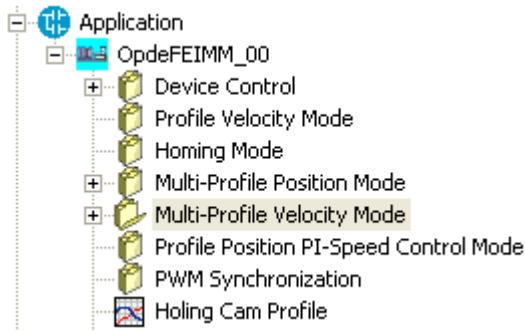

Multi-Profile Velocity mode allows realizing a multi step-speed profile with up to 10 different speeds, the change of the speed depends on the position of the motor or the position received from the CAN2. The user can also choose different steps of limit torque. Position Loop is not enabled, the system works only in speed mode.

The structure of Multi-Profile Velocity Mode is similar to Multi-Profile Position. There is the possibility to choose a positive profile or a negative profile. The position to change speed, torque, speeds references, torque references, accelerations are the same of Multi-Profile Position.

In the FEIMM this operative method can control the Screw Axes during Dosing: Injection Axes after suck-back jump in Profile Position PI-Speed Control mode and send the position to screw by CAN2 communication. Screw Axes changes speed and torque depending on the position received.

Name	Description	Min	Max	Default	UM	Scale	index	Type	Access
rCONTROL_WORD	E100 – Control Word			0000		1	CAN: 0x6040	UNSIGNED D16	R/W
							MODBUS: 0x2000		
STATUS_WORD	d64 – Status Word			0000		1	0x6041	UNSIGNED D16	R/W
							0x03C0		
RD_STATE_MACHINE	E101 – Finite State Machine					1		UNSIGNED D16	R
							0x2001		
pMODE_OF_OP	E01 – Mode of operations	Range		3		1	0x6060	INTEGER8	R/W
		1	1-Profile Position Mode						
		2	2-Multi Profile Position Mode						
		3	3-Profile Velocity Mode						
		4	4-Profile Velocity Mode with PI control						
6	6-Homing mode								
MODE_OF_OP_DIS	d65 – Modes of operation display					1	0x6061	INTEGER8	R
							0x03C1		
pQSDEC	E08 – 09 – Quick stop deceleration	10223	2147483647	1638400	ie/s <sup>2</sup>	1	0x3102 sub 0x04	INTEGER3 2	R/W
							0x0134 – 0x0135		
pQSOPTC	E38 – Quick Stop Option Code	Range				1	0x3102	INTEGER3 2	R/W
		0							

Name	Description	Min	Max	Default	UM	Scale	index	Type	Access	
		2	2 – Switch On Disabled				sub 0x13 (16 lsb)			
		6	6 – Stay in Quick Stop				0x0152			
		8								
pTHRVEL	E18 - Velocity threshold	100	65535	10000	ie/s	1	0x3102 sub 0x09 (16 lsb) 0x013E	NTEGER3 2	R/W	
pTIMEVEL	E20 - Velocity threshold time	0	65535	0	ms	1	0x3102 sub 0x0A (16 lsb) 0x0140	NTEGER3 2	R/W	
pWINVEL	E22 - Velocity window	0	65535	0	ie/s	1	0x3102 sub 0x0B (16 lsb) 0x0142	NTEGER3 2	R/W	
pWTIMEVEL	E24 - Velocity window time-out	0	65535	0	ms	1	0x3102 sub 0x0C (16 lsb) 0x0144	NTEGER3 2	R/W	
ACTUALPOS	d66-67 – Position actual value				ie	1	0x6064 0x03C2 - 0x03C3	INTEGER 32	R	
ACTUALVEL	d68-69 – Velocity actual value				ie/s	1	0x606C 0x03C4 - 0x03C5	INTEGER3 2	R	
MAX_SPEED_IE	d72-73 – Speed Max [ie] (P65 – MOT_MAX_SPEED)				ie/s	1	0x200F sub 0x48 0x03C8 – 0x03C9	INTEGER3 2	R	
pENSPDFW	E36 - Enable Speed Feed-forward	0	1	1		1	0x3102 sub 0x12 (16 lsb) 0x0150	INTEGER3 2	R/W	
pENTRQFDW	E37 - Enable Torque Feed-forward	0	1	1		1	0x3102 sub 0x12 (16 msb) 0x0151	INTEGER3 2	R/W	
PrfPP_Pos_PosTrg	E448 - 449 - Positive Profile Position Target	- 21474 83648	214748364 7	0	ie	1	0x3006 sub 0x00 0x215C – 0x215d	INTEGER3 2	R	
PrfPP_Neg_PosTrg	E704 - 705 – Negative Profile Position Target	- 21474 83648	214748364 7	0	ie		0x3016 sub 0x00 0x225C – 0x225D	INTEGER3 2	R	
Can2_Selection	E899 - Position selection in Multi-Profile Position Mode	Range					1	MODBUS: 0x231F	NTEGER3 2	R/W
		0	0 - Use motor position							
		1	1 - Send Pos by CAN 2							
		2	2 - Receive position by CAN 2							
		3	3 - Send Torque and position by SPI (Master)							
4	4 - Receive Pos by SPI (Slave)									

Name	Description	Min	Max	Default	UM	Scale	index	Type	Access
Can2_Tx_COB_ID	E900 - Transmitter COB-ID	0	127	0		1	0x2400	INTEGER16	R/W
Can2_Rx_COB_ID	E901 - Receiver COB-ID	0	127	0		1	0x2401	INTEGER16	R/W
ACTUALPOS_CAN2	d75 - d76 - Position received from CAN2				ie	1	0x200F sub 0x4B 0x03CB – 0x03CC	INTEGER32	R
STATUS_WORD2	d74 - STATUS_WORD2			0x000		1	0x200F sub 0x4A 0x03CA	UNSIGNED16	R

Tab. 20- Multi-Profile Velocity Mode

## 2.7.1 VELOCITY PROFILE POSITIVE

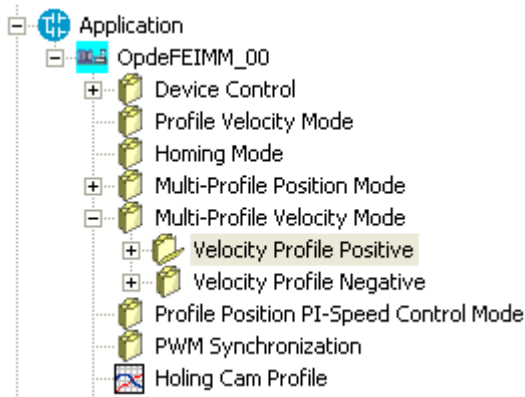

Name	Description	Min	Max	Default	UM	Scale	index	Type	Access
rCONTROL_WORD	E100 – Control Word			0000		1	CAN: 0x6040	UNSIGNED16	R/W
							MODBUS: 0x2000		
STATUS_WORD	d64 – Status Word			0000		1	0x6041	UNSIGNED16	R/W
							0x03C0		
RD_STATE_MACHINE	E101 – Finite State Machine					1	0x2001	UNSIGNED16	R
pMODE_OF_OP	E01 – Mode of operations	Range		3		1	0x6060	INTEGER8	R/W
		1	1-Profile Position Mode						
		2	2-Multi Profile Position Mode						
		3	3-Profile Velocity Mode						
		4	4-Profile Velocity Mode with PI control						
6	6-Homing mode								

Name	Description	Min	Max	Default	UM	Scale	index	Type	Access
MODE_OF_OP_DIS	d65 – Modes of operation display					1	0x6061	INTEGER8	R
							0x03C1		
ACTUALPOS	d66-67 – Position actual value				ie	1	0x6064	INTEGER32	R
							0x03C2 - 0x03C3		
ACTUALVEL	d68-69 – Velocity actual value				ie/s	1	0x606C	INTEGER32	R
							0x03C4 - 0x03C5		
MAX_SPEED_IE	d72-73 – Speed Max [ie] (P65 – MOT_MAX_SPEED)				ie/s	1	0x200F sub 0x48	INTEGER32	R
							0x03C8 – 0x03C9		
PrfPP_Pos_PosTrg	E448 - 449 - Positive Profile Position Target	- 2147483648	2147483647	0	ie	1	0x3006 sub 0x00	INTEGER32	R
							0x215C – 0x215d		

Tab. 21- Velocity Positive Profile

### 2.7.1.0 Speed Positive Multi Profile

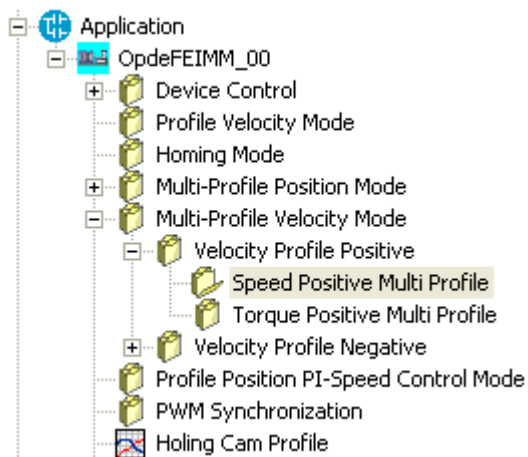

Name	Description	Min	Max	Default	UM	Scale	index	Type	Access
PrfPP_Pos_Pos ChgSpd_0	E356 - 357 - 0 - Positive Profile Position Targhet/Change Speed	- 2147483648	2147483647	0	ie	1	CAN: 0x3000 sub 0x00	INTEGER32	R/W
							MODBUS: 0x2100-0x2101		
PrfPP_Pos_Pos ChgSpd_1	E358 - 359 - 1 - Positive Profile Position Targhet/Change Speed	- 2147483648	2147483647	0	ie	1	0x3000 sub 0x01	INTEGER32	R/W
							0x2102-0x2103		
PrfPP_Pos_Pos ChgSpd_2	E360 - 361 - 2 - Positive Profile Position Targhet/Change Speed	- 2147483648	2147483647	0	ie	1	0x3000 sub 0x02	INTEGER32	R/W
							0x2104-0x2105		

Name	Description	Min	Max	Default	UM	Scale	index	Type	Access
PrfPP_Pos_Pos ChgSpd_3	E362 - 363 - 3 - Positive Profile Position Targhet/Change Speed	-	2147483648	0	ie	1	0x3000 sub 0x03	INTEGER32	R/W
							0x2106- 0x2107		
PrfPP_Pos_Pos ChgSpd_4	E364 - 365 - 4 - Positive Profile Position Targhet/Change Speed	-	2147483648	0	ie	1	0x3000 sub 0x04	INTEGER32	R/W
							0x2108- 0x2109		
PrfPP_Pos_Pos ChgSpd_5	E366 - 367 - 5 - Positive Profile Position Targhet/Change Speed	-	2147483648	0	ie	1	0x3000 sub 0x05	INTEGER32	R/W
							0x210A- 0x210B		
PrfPP_Pos_Pos ChgSpd_6	E368 - 369 - 6 - Positive Profile Position Targhet/Change Speed	-	2147483648	0	ie	1	0x3000 sub 0x06	INTEGER32	R/W
							0x210C- 0x210D		
PrfPP_Pos_Pos ChgSpd_7	E370 - 371 - 7 - Positive Profile Position Targhet/Change Speed	-	2147483648	0	ie	1	0x3000 sub 0x07	INTEGER32	R/W
							0x210E- 0x210F		
PrfPP_Pos_Pos ChgSpd_8	E372 - 373 - 8 - Positive Profile Position Targhet/Change Speed	-	2147483648	0	ie	1	0x3000 sub 0x08	INTEGER32	R/W
							0x2110- 0x2111		
PrfPP_Pos_Pos ChgSpd_9	E374 - 375 - 9 - Positive Profile Position Targhet/Change Speed	-	2147483648	0	ie	1	0x3000 sub 0x08	INTEGER32	R/W
							0x2112- 0x2113		
PrfPP_Pos_Spe ed_0	E378 - 379 - 0 - Profile Positive Speed	0	2147483648	0	ie/s	1	0x3001 sub 0x00	INTEGER32	R/W
							0x2116- 0x2117		
PrfPP_Pos_Spe ed_1	E380 - 381 - 1 - Profile Positive Speed	0	2147483648	0	ie/s	1	0x3001 sub 0x01	INTEGER32	R/W
							0x2118- 0x2119		
PrfPP_Pos_Spe ed_2	E382 - 383 - 2 - Profile Positive Speed	0	2147483648	0	ie/s	1	0x3001 sub 0x02	INTEGER32	R/W
							0x211A- 0x211B		
PrfPP_Pos_Spe ed_3	E384 - 385 - 3 - Profile Positive Speed	0	2147483648	0	ie/s	1	0x3001 sub 0x03	INTEGER32	R/W
							0x211C- 0x211D		
PrfPP_Pos_Spe ed_4	E386 - 387 - 4 - Profile Positive Speed	0	2147483648	0	ie/s	1	0x3001 sub 0x04	INTEGER32	R/W
							0x211E- 0x211F		
PrfPP_Pos_Spe ed_5	E388 - 389 - 5 - Profile Positive Speed	0	2147483648	0	ie/s	1	0x3001 sub 0x05	INTEGER32	R/W
							0x2120- 0x2121		
PrfPP_Pos_Spe ed_6	E390 - 391 - 6 - Profile Positive Speed	0	2147483648	0	ie/s	1	0x3001 sub 0x06	INTEGER32	R/W
							0x2122- 0x2123		
PrfPP_Pos_Spe ed_7	E392 - 393 - 7 - Profile Positive Speed	0	2147483648	0	ie/s	1	0x3001 sub 0x07	INTEGER32	R/W
							0x2124- 0x2125		
PrfPP_Pos_Spe ed_8	E394 - 395 - 8 - Profile Positive Speed	0	2147483648	0	ie/s	1	0x3001 sub 0x08	INTEGER32	R/W
							0x2126-		



Name	Description	Min	Max	Default	UM	Scale	index	Type	Access
							0x2127		
PrfPP_Pos_Speed_9	E396 - 397 - 9 - Profile Positive Speed	0	2147483647	0	ie/s	1	0x3001 sub 0x09	INTEGER32	R/W
							0x2128-0x2129		
PrfPP_Pos_Acc_Dec_0	E510 – 511 – Positive Profile Acc Dec 0	10223	2147483647	500000	ie/s <sup>2</sup>	1	0x300a sub 0x00	INTEGER32	R/W
							0x219a – 0x219b		
PrfPP_Pos_Acc_Dec_1	E512 – 513 – Positive Profile Acc Dec 1	10223	2147483647	500000	ie/s <sup>2</sup>	1	0x300a sub 0x01	INTEGER32	R/W
							0x219c – 0x219d		
PrfPP_Pos_Acc_Dec_2	E514 – 515 – Positive Profile Acc Dec 2	10223	2147483647	500000	ie/s <sup>2</sup>	1	0x300a sub 0x02	INTEGER32	R/W
							0x219e – 0x219f		
PrfPP_Pos_Acc_Dec_3	E516 – 517 – Positive Profile Acc Dec 3	10223	2147483647	500000	ie/s <sup>2</sup>	1	0x300a sub 0x03	INTEGER32	R/W
							0x21a0 – 0x21a1		
PrfPP_Pos_Acc_Dec_4	E518 – 519 – Positive Profile Acc Dec 4	10223	2147483647	500000	ie/s <sup>2</sup>	1	0x300a sub 0x04	INTEGER32	R/W
							0x21a2 – 0x21a3		
PrfPP_Pos_Acc_Dec_5	E520 – 521 – Positive Profile Acc Dec 5	10223	2147483647	500000	ie/s <sup>2</sup>	1	0x300a sub 0x05	INTEGER32	R/W
							0x21a4 – 0x21a5		
PrfPP_Pos_Acc_Dec_6	E522 – 523 – Positive Profile Acc Dec 6	10223	2147483647	500000	ie/s <sup>2</sup>	1	0x300a sub 0x06	INTEGER32	R/W
							0x21a6 – 0x21a7		
PrfPP_Pos_Acc_Dec_7	E524 – 525 – Positive Profile Acc Dec 7	10223	2147483647	500000	ie/s <sup>2</sup>	1	0x300a sub 0x07	INTEGER32	R/W
							0x21a8 – 0x21a9		
PrfPP_Pos_Acc_Dec_8	E526 – 527 – Positive Profile Acc Dec 8	10223	2147483647	500000	ie/s <sup>2</sup>	1	0x300a sub 0x08	INTEGER32	R/W
							0x21aa – 0x21ab		
PrfPP_Pos_Acc_Dec_9	E528 – 529 – Positive Profile Acc Dec 9	10223	2147483647	500000	ie/s <sup>2</sup>	1	0x300a sub 0x09	INTEGER32	R/W
							0x21ac – 0x21ad		
PrfPP_Pos_Final_Dec	E530 – 531 – Positive Profile Acc Dec 4	10223	2147483647	500000	ie/s <sup>2</sup>	1	0x300a sub 0x0a		R/W
							0x21ae – 0x21af		
PrfPP_Pos_NrPrfSpd	E400 - Positive Profile Nr. Change Speed	0	8	0		1	0x300C sub 0x01	INTEGER 8	R/W
							0x212C		
MAX_SPEED_I_E	d72-73 – Speed Max [ie] (P65 – MOT_MAX_SPEED)				ie/s		0x200F sub 0x48		R
							0x03C9 – 0x03C9		
PrfPP_Pos_IndTargPos	E401 - Index of Positive Profile Position Targhet	0	9	9		1	0x300C sub 0x00	INTEGER 8	R/W
							0x212D		

Tab. 22- Speed Positive Multi-Profile

### 2.7.1.1 Torque Positive Multi Profile

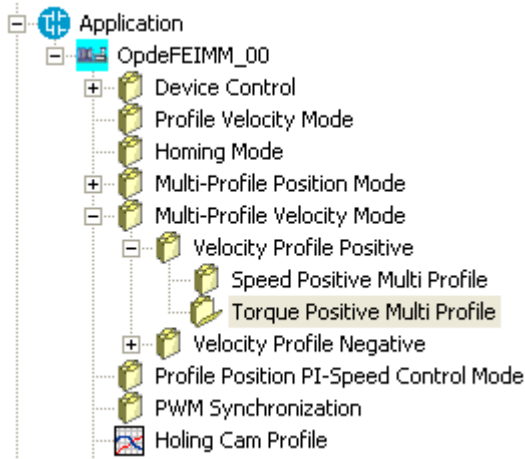

Name	Description	Min	Max	Default	UM	Scale	index	Type	Access		
PrfPP_Neg_Pos ChgTrq_0	E658 - 659 - 0 - Profile Negative Position Change Torque	-	2147483648	-	2147483647	0	ie	1	CAN: 0x3013 sub 0x00	INTEGER 32	R/W
									MODBUS: 0x222E – 0x222F		
PrfPP_Neg_Pos ChgTrq_1	E660 - 661 - 1 - Profile Negative Position Change Torque	-	2147483648	-	2147483647	0	ie	1	0x3013 sub 0x01	INTEGER 32	R/W
									0x2230 – 0x2231		
PrfPP_Neg_Pos ChgTrq_2	E662 - 663 - 2 - Profile Negative Position Change Torque	-	2147483648	-	2147483647	0	ie	1	0x3013 sub 0x02	INTEGER 32	R/W
									0x2232 – 0x2233		
PrfPP_Neg_Pos ChgTrq_3	E664 - 665 - 3 - Profile Negative Position Change Torque	-	2147483648	-	2147483647	0	ie	1	0x3013 sub 0x03	INTEGER 32	R/W
									0x2234 – 0x2235		
PrfPP_Neg_Pos ChgTrq_4	E666 - 667 - 4 - Profile Negative Position Change Torque	-	2147483648	-	2147483647	0	ie	1	0x3013 sub 0x04	INTEGER 32	R/W
									0x2236 – 0x2237		
PrfPP_Neg_Pos ChgTrq_5	E668 - 669 - 5 - Profile Negative Position Change Torque	-	2147483648	-	2147483647	0	ie	1	0x3013 sub 0x05	INTEGER 32	R/W
									0x2238 – 0x2239		
PrfPP_Neg_Pos ChgTrq_6	E670 - 671 - 6 - Profile Negative Position Change Torque	-	2147483648	-	2147483647	0	ie	1	0x3013 sub 0x06	INTEGER 32	R/W
									0x223A – 0x223B		
PrfPP_Neg_Pos ChgTrq_7	E672 - 673 - 7 - Profile Negative Position Change Torque	-	2147483648	-	2147483647	0	ie	1	0x3013 sub 0x07	INTEGER 32	R/W
									0x223C – 0x223D		
PrfPP_Neg_Pos ChgTrq_8	E674 - 675 - 8 - Profile Positive Position Change Torque	-	2147483648	-	2147483647	0	ie	1	0x3013 sub 0x08	INTEGER 32	R/W
									0x223E – 0x223F		
PrfPP_Neg_Torque_0	E681 - 0 - Profile Negative Limit Torque	0.00	400.00	0.00	% MOT_T_N	100	0x3014	UNSIGNED 16	R/W		

Name	Description	Min	Max	Default	UM	Scale	index	Type	Access
					OM		sub 0x00		
							0x2245		
PrfPP_Neg_Torque_1	E682 - 1 - Profile Negative Limit Torque	0.00	400.00	0.00	% MOT_T_N OM	100	0x3014 sub 0x01	UNSIGNED 16	R/W
							0x2246		
PrfPP_Neg_Torque_2	E683 - 2 - Profile Negative Limit Torque	0.00	400.00	0.00	% MOT_T_N OM	100	0x3014 sub 0x02	UNSIGNED 16	R/W
							0x2247		
PrfPP_Neg_Torque_3	E684 - 3 - Profile Negative Limit Torque	0.00	400.00	0.00	% MOT_T_N OM	100	0x3014 sub 0x03	UNSIGNED 16	R/W
							0x2248		
PrfPP_Neg_Torque_4	E685 - 4 - Profile Negative Limit Torque	0.00	400.00	0.00	% MOT_T_N OM	100	0x3014 sub 0x04	UNSIGNED 16	R/W
							0x2249		
PrfPP_Neg_Torque_5	E686 - 5 - Profile Negative Limit Torque	0.00	400.00	0.00	% MOT_T_N OM	100	0x3014 sub 0x05	UNSIGNED 16	R/W
							0x224A		
PrfPP_Neg_Torque_6	E687 - 6 – Profile Negative Limit Torque	0.00	400.00	0.00	% MOT_T_N OM	100	0x3014 sub 0x06	UNSIGNED 16	R/W
							0x224B		
PrfPP_Neg_Torque_7	E688 - 7 - Profile Negative Limit Torque	0.00	400.00	0.00	% MOT_T_N OM	100	0x3014 sub 0x07	UNSIGNED 16	R/W
							0x224C		
PrfPP_Neg_Torque_8	E689 - 8 - Profile Negative Limit Torque	0.00	400.00	0.00	% MOT_T_N OM	100	0x3014 sub 0x08	UNSIGNED 16	R/W
							0x224D		
PrfPP_Neg_Torque_9	E690- 9 - Profile Negative Limit Torque	0.00	400.00	0.00	% MOT_T_N OM	100	0x3014 sub 0x09	UNSIGNED 16	R/W
							0x224E		
PrfPP_Neg_NrPrfTrq	E703 - Negative Profile Nr. Change Limit Torque	0	8	0		1	0x301C sub 0x02	INTEGER 8	R/W
							0x225B		

Tab. 23- Torque Positive Multi-Profile

## 2.7.2 VELOCITY PROFILE NEGATIVE

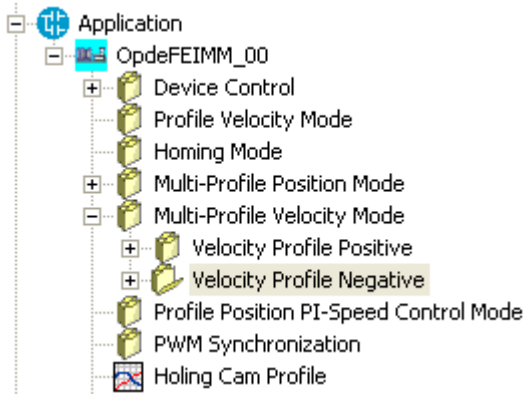

Name	Description	Min	Max	Default	UM	Scale	index	Type	Access
rCONTROL_WORD	E100 – Control Word			0000		1	CAN: 0x6040	UNSIGNED D16	R/W
							MODBUS: 0x2000		
STATUS_WORD	d64 – Status Word			0000		1	0x6041	UNSIGNED D16	R/W
							0x03C0		
RD_STATE_MACHINE	E101 – Finite State Machine					1		UNSIGNED D16	R
							0x2001		
pMODE_OF_OP	E01 – Mode of operations	Range		3		1	0x6060	INTEGER8	R/W
		1	1-Profile Position Mode						
		2	2-Multi Profile Position Mode						
		3	3-Profile Velocity Mode						
		4	4-Profile Velocity Mode with PI control						
		6	6-Homing mode						
MODE_OF_OP_DIS	d65 – Modes of operation display					1	0x6061	INTEGER8	R
							0x03C1		
ACTUALPOS	d66-67 – Position actual value				ie	1	0x6064	INTEGER 32	R
							0x03C2 - 0x03C3		
ACTUALVEL	d68-69 – Velocity actual value				ie/s	1	0x606C	INTEGER3 2	R
							0x03C4 - 0x03C5		
MAX_SPEED_IE	d72-73 – Speed Max [ie] (P65 – MOT_MAX_SPEED)				ie/s	1	0x200F sub 0x48	INTEGER3 2	R
							0x03C8 – 0x03C9		
PrfPP_Neg_PosTrg	E704 - 705 - Negative Profile Position Target	- 21474 83648	214748364 7	0	ie	1	0x3006 sub 0x00	INTEGER3 2	R
							0x215C – 0x215d		

Tab. 24- Velocity Profile Negative

## 2.7.2.0 Speed Negative Multi Profile

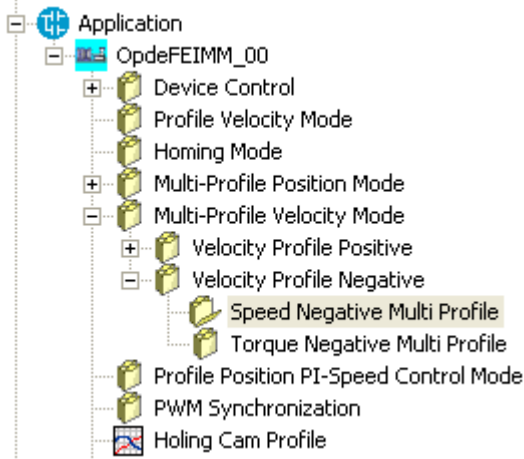

Name	Description	Min	Max	Default	UM	Scale	index	Type	Access
PrfPP_Neg_Pos ChgSpd_0	E612 - 613 - 0 - Negative Profile Position Targhet/Change Speed	-	2147483 647	0	ie	1	CAN: 0x3010 sub 0x00	INTEGER 32	R/W
							MODBUS: 0x2200 – 0x2201		
PrfPP_Neg_Pos ChgSpd_1	E614 - 615 - 1 - Negative Profile Position Targhet/Change Speed	-	2147483 647	0	ie	1	0x3010 sub 0x01	INTEGER 32	R/W
							0x2202 – 0x2203		
PrfPP_Neg_Pos ChgSpd_2	E616 - 617 - 2 - Negative Profile Position Targhet/Change Speed	-	2147483 647	0	ie	1	0x3010 sub 0x02	INTEGER 32	R/W
							0x2204 – 0x2205		
PrfPP_Neg_Pos ChgSpd_3	E618 - 619 - 3 - Negative Profile Position Targhet/Change Speed	-	2147483 647	0	ie	1	0x3010 sub 0x03	INTEGER 32	R/W
							0x2206 – 0x2207		
PrfPP_Neg_Pos ChgSpd_4	E620 - 621 - 4 - Negative Profile Position Targhet/Change Speed	-	2147483 647	0	ie	1	0x3010 sub 0x04	INTEGER 32	R/W
							0x2208 – 0x2209		
PrfPP_Neg_Pos ChgSpd_5	E622 - 623 - 5 - Profile Position Targhet/Change Speed	-	2147483 647	0	ie	1	0x3010 sub 0x05	INTEGER 32	R/W
							0x220A – 0x220B		
PrfPP_Neg_Pos ChgSpd_6	E624 - 625 - 6 - Negative Profile Position Targhet/Change Speed	-	2147483 647	0	ie	1	0x3010 sub 0x06	INTEGER 32	R/W
							0x220C – 0x220D		
PrfPP_Neg_Pos ChgSpd_7	E626 - 627 - 7 - Negative Profile Position Targhet/Change Speed	-	2147483 647	0	ie	1	0x3010 sub 0x07	INTEGER 32	R/W
							0x220E – 0x220F		
PrfPP_Neg_Pos ChgSpd_8	E628 - 629 - 8 - Negative Profile Position Targhet/Change Speed	-	2147483 647	0	ie	1	0x3010 sub 0x08	INTEGER 32	R/W
							0x2210 – 0x2211		
PrfPP_Neg_Pos ChgSpd_9	E630 - 631 - 9 - Negative Profile Position Targhet/Change Speed	-	2147483 647	0	ie	1	0x3010 sub 0x09	INTEGER 32	R/W
							0x2212 – 0x2213		

Name	Description	Min	Max	Default	UM	Scale	index	Type	Access
PrfPP_Neg_Speed_0	E634 - 635 - 0 - Profile Negative Speed	0	2147483 647	0	ie/s	1	0x3011 sub 0x00	INTEGER 32	R/W
							0x2216 – 0x2217		
PrfPP_Neg_Speed_1	E636 - 637 - 1 - Profile Negative Speed	0	2147483 647	0	ie/s	1	0x3011 sub 0x01	INTEGER 32	R/W
							0x2218 – 0x2219		
PrfPP_Neg_Speed_2	E638 - 639 - 2 - Profile Negative Speed	0	2147483 647	0	ie/s	1	0x3011 sub 0x02	INTEGER 32	R/W
							0x221A – 0x221B		
PrfPP_Neg_Speed_3	E640 - 641 - 3 – Profile Negative Speed	0	2147483 647	0	ie/s	1	0x3011 sub 0x03	INTEGER 32	R/W
							0x221C – 0x221D		
PrfPP_Neg_Speed_4	E642 - 643 - 4 - Profile Negative Speed	0	2147483 647	0	ie/s	1	0x3011 sub 0x04	INTEGER 32	R/W
							0x221E – 0x221F		
PrfPP_Neg_Speed_5	E644 - 645 - 5 - Profile Negative Speed	0	2147483 647	0	ie/s	1	0x3011 sub 0x05	INTEGER 32	R/W
							0x2220 – 0x2221		
PrfPP_Neg_Speed_6	E646 - 647 - 6 - Profile Negative Speed	0	2147483 647	0	ie/s	1	0x3011 sub 0x06	INTEGER 32	R/W
							0x2222 – 0x2223		
PrfPP_Neg_Speed_7	E648 - 649 - 7 - Profile Negative Speed	0	2147483 647	0	ie/s	1	0x3011 sub 0x07	INTEGER 32	R/W
							0x2224 – 0x2225		
PrfPP_Neg_Speed_8	E650 - 651 - 8 - Profile Negative Speed	0	2147483 647	0	ie/s	1	0x3011 sub 0x08	INTEGER 32	R/W
							0x2226 – 0x2227		
PrfPP_Neg_Speed_9	E652 - 653 - 9 - Profile Negative Speed	0	2147483 647	0	ie/s	1	0x3011 sub 0x09	INTEGER 32	R/W
							0x2228 – 0x2229		
PrfPP_Neg_Acc_Dec_0	E510 – 511 – Negative Profile Acc Dec 0	10223	2147483 647	5000 00	ie/s <sup>2</sup>	1	0x301A sub 0x00	INTEGER 32	R/W
							0x229a- 0x229b		
PrfPP_Neg_Acc_Dec_1	E512 – 513 – Negative Profile Acc Dec 1	10223	2147483 647	5000 00	ie/s <sup>2</sup>	1	0x301A sub 0x01	INTEGER 32	R/W
							0x229c – 0x229d		
PrfPP_Neg_Acc_Dec_2	E514 – 515 – Negative Profile Acc Dec 2	10223	2147483 647	5000 00	ie/s <sup>2</sup>	1	0x301A sub 0x02	INTEGER 32	R/W
							0x229e – 0x229f		
PrfPP_Neg_Acc_Dec_3	E516 – 517 – Negative Profile Acc Dec 3	10223	2147483 647	5000 00	ie/s <sup>2</sup>	1	0x301A sub 0x03	INTEGER 32	R/W
							0x22a0 – 0x22a1		
PrfPP_Neg_Acc_Dec_4	E518 – 519 – Negative Profile Acc Dec 4	10223	2147483 647	5000 00	ie/s <sup>2</sup>	1	0x301A sub 0x04	INTEGER 32	R/W
							0x22a2 – 0x22a3		
PrfPP_Neg_Acc_Dec_5	E520 – 521 – Negative Profile Acc Dec 5	10223	2147483 647	5000 00	ie/s <sup>2</sup>	1	0x301A sub 0x05	INTEGER 32	R/W
							0x22a4 –		

Name	Description	Min	Max	Default	UM	Scale	index	Type	Access
							0x22a5		
PrfPP_Neg_Acc_Dec_6	E522 – 523 – Negative Profile Acc Dec 6	10223	2147483647	500000	ie/s <sup>2</sup>	1	0x301A sub 0x06	INTEGER 32	R/W
							0x22a6 – 0x22a7		
PrfPP_Neg_Acc_Dec_7	E524 – 525 – Negative Profile Acc Dec 7	10223	2147483647	500000	ie/s <sup>2</sup>	1	0x301A sub 0x07	INTEGER 32	R/W
							0x22a8 – 0x22a9		
PrfPP_Neg_Acc_Dec_8	E526 – 527 – Negative Profile Acc Dec 8	10223	2147483647	500000	ie/s <sup>2</sup>	1	0x301A sub 0x08	INTEGER 32	R/W
							0x22aa – 0x22ab		
PrfPP_Neg_Acc_Dec_9	E528 – 529 – Negative Profile Acc Dec 9	10223	2147483647	500000	ie/s <sup>2</sup>	1	0x301A sub 0x09	INTEGER 32	R/W
							0x22ac – 0x22ad		
PrfPP_Neg_Final_Dec	E530 – 531 – Negative Profile Final Deceleration	10223	2147483647	500000	ie/s <sup>2</sup>	1	0x301A sub 0x0a	INTEGER 32	R/W
							0x22ae – 0x22af		
PrfPP_Neg_NrPrfSpd	E656 - Negative Profile Nr. Change Speed	0	8	0		1	0x301C sub 0x01	INTEGER 8	R/W
							0x222C		
MAX_SPEED_LIMIT	d72-73 – Speed Max [ie] (P65 – MOT_MAX_SPEED)				ie/s		0x200F sub 0x48	INTEGER32	R
							0x03C8 – 0x03C9		
PrfPP_Neg_IndTrgPos	E657 - Index of Negative Profile Position Target	0	9	9		1	0x301C sub 0x00	INTEGER 8	R/W
							0x222D		

Tab. 25- Speed Negative Multi-profile

### 2.7.2.1 Torque Negative Multi Profile

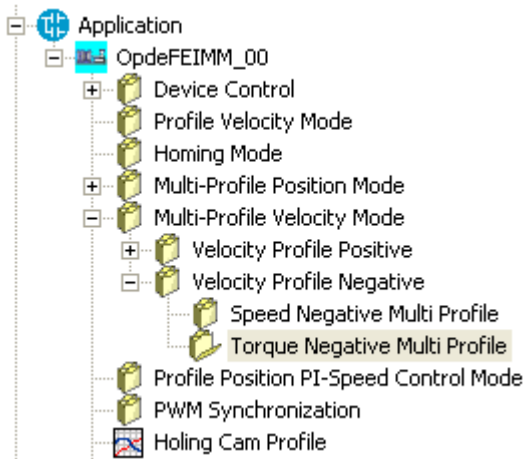

Name	Description	Min	Max	Default	UM	Scale	index	Type	Access
PrfPP_Neg_Pos ChgTrq_0	E658 - 659 - 0 - Profile Negative Position Change Torque	-	21474836 47	0	ie	1	CAN: 0x3013 sub 0x00	INTEGER 32	R/W
							MODBUS: 0x222E – 0x222F		
PrfPP_Neg_Pos ChgTrq_1	E660 - 661 - 1 - Profile Negative Position Change Torque	-	21474836 47	0	ie	1	0x3013 sub 0x01	INTEGER 32	R/W
							0x2230 – 0x2231		
PrfPP_Neg_Pos ChgTrq_2	E662 - 663 - 2 - Profile Negative Position Change Torque	-	21474836 47	0	ie	1	0x3013 sub 0x02	INTEGER 32	R/W
							0x2232 – 0x2233		
PrfPP_Neg_Pos ChgTrq_3	E664 - 665 - 3 - Profile Negative Position Change Torque	-	21474836 47	0	ie	1	0x3013 sub 0x03	INTEGER 32	R/W
							0x2234 – 0x2235		
PrfPP_Neg_Pos ChgTrq_4	E666 - 667 - 4 - Profile Negative Position Change Torque	-	21474836 47	0	ie	1	0x3013 sub 0x04	INTEGER 32	R/W
							0x2236 – 0x2237		
PrfPP_Neg_Pos ChgTrq_5	E668 - 669 - 5 - Profile Negative Position Change Torque	-	21474836 47	0	ie	1	0x3013 sub 0x05	INTEGER 32	R/W
							0x2238 – 0x2239		
PrfPP_Neg_Pos ChgTrq_6	E670 - 671 - 6 - Profile Negative Position Change Torque	-	21474836 47	0	ie	1	0x3013 sub 0x06	INTEGER 32	R/W
							0x223A – 0x223B		
PrfPP_Neg_Pos ChgTrq_7	E672 - 673 - 7 - Profile Negative Position Change Torque	-	21474836 47	0	ie	1	0x3013 sub 0x07	INTEGER 32	R/W
							0x223C – 0x223D		
PrfPP_Neg_Pos ChgTrq_8	E674 - 675 - 8 - Profile Positive Position Change Torque	-	21474836 47	0	ie	1	0x3013 sub 0x08	INTEGER 32	R/W
							0x223E – 0x223F		
PrfPP_Neg_Torque_0	E681 - 0 - Profile Negative Limit Torque	0.00	400.00	0.00	% MOT_T_N OM	100	0x3014 sub 0x00	UNSIGNED 16	R/W
							0x2245		
PrfPP_Neg_Torque_1	E682 - 1 - Profile Negative Limit Torque	0.00	400.00	0.00	% MOT_T_N OM	100	0x3014 sub 0x01	UNSIGNED 16	R/W
							0x2246		
PrfPP_Neg_Torque_2	E683 - 2 - Profile Negative Limit Torque	0.00	400.00	0.00	% MOT_T_N OM	100	0x3014 sub 0x02	UNSIGNED 16	R/W
							0x2247		
PrfPP_Neg_Torque_3	E684 - 3 - Profile Negative Limit Torque	0.00	400.00	0.00	% MOT_T_N OM	100	0x3014 sub 0x03	UNSIGNED 16	R/W
							0x2248		
PrfPP_Neg_Torque_4	E685 - 4 - Profile Negative Limit Torque	0.00	400.00	0.00	% MOT_T_N OM	100	0x3014 sub 0x04	UNSIGNED 16	R/W
							0x2249		
PrfPP_Neg_Torque_5	E686 - 5 - Profile Negative Limit Torque	0.00	400.00	0.00	% MOT_T_N OM	100	0x3014 sub 0x05	UNSIGNED 16	R/W
							0x224A		
PrfPP_Neg_Torque_6	E687 - 6 – Profile Negative Limit Torque	0.00	400.00	0.00	% MOT_T_N OM	100	0x3014 sub 0x06	UNSIGNED 16	R/W
							0x224B		
PrfPP_Neg_Torque_7	E688 - 7 - Profile Negative Limit Torque	0.00	400.00	0.00	% MOT_T_N OM	100	0x3014 sub 0x07	UNSIGNED 16	R/W



Name	Description	Min	Max	Default	UM	Scale	index	Type	Access
					OM		0x224C		
PrfPP_Neg_Torque_8	E689 - 8 - Profile Negative Limit Torque	0.00	400.00	0.00	% MOT_T_NOM	100	0x3014 sub 0x08 0x224D	UNSIGNED 16	R/W
PrfPP_Neg_Torque_9	E690- 9 - Profile Negative Limit Torque	0.00	400.00	0.00	% MOT_T_NOM	100	0x3014 sub 0x09 0x224E	UNSIGNED 16	R/W
PrfPP_Neg_NrPrfTrq	E703 - Negative Profile Nr. Change Limit Torque	0	8	0		1	0x301C sub 0x02 0x225B	INTEGER 8	R/W

Tab. 26- Torque Negative Multi-profile

## 2.8 PROFILE VELOCITY PI CONTROL MODE

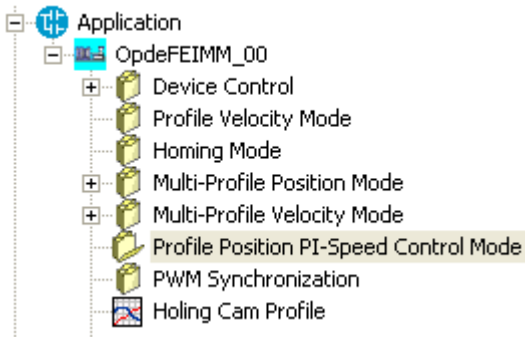

Profile velocity PI control mode creates a position reference depending on the actual analogue input value selected with **PrfPP\_Pos\_SeIAI\_StartHoldCam\_PV**. Position reference is created like output from a PI controller.

In the FEIMM this operative method can control the Screw Axes during Dosing.

Name	Description	Min	Max	Default	UM	Scale	index	Type	Access
rCONTROL_WORD	E100 – Control Word			0000		1	CAN: 0x6040 MODBUS: 0x2000	UNSIGNED 16	R/W
STATUS_WORD	d64 – Status Word			0000		1	0x6041 0x03C0	UNSIGNED 16	R/W
RD_STATE_MACHINE	E101 – Finite State Machine					1	0x2001	UNSIGNED 16	R
pMODE_OF_OP	E01 – Mode of operations	Range		3		1	0x6060	INTEGER 8	R/W
		1	1-Profile Position Mode						
		2	2-Multi Profile Position Mode						
		3	3-Profile Velocity Mode						
4	4-Profile Velocity Mode with PI	0x012D							

Name	Description	Min	Max	Default	UM	Scale	index	Type	Access
		control							
		6	6-Homing mode						
MODE_OF_OP_DIS	d65 – Modes of operation display						0x6061	INTEGER8	R
							0x03C1		
pTARGETVEL	E02-03 – Target Velocity	- 21474 83648	214748364 7	32768	ie/s		0x3102 sub 0x01	INTEGER32	R/W
							0x012E – 0x012F		
pPROFACC	E04-E05 - Profile acceleration	10223	214748364 7	50000 0	ie/s <sup>2</sup>	1	0x3102 sub 0x02	INTEGER32	R/W
							0x0130 – 0x0131		
pPROFDEC	E06-E07 - Profile deceleration	10223	214748364 7	50000 0	ie/s <sup>2</sup>	1	0x3102 sub 0x03	INTEGER32	R/W
							0x0132 – 0x0133		
pQSDEC	E08 – 09 – Quick stop deceleration	10223	214748364 7	16384 00	ie/s <sup>2</sup>	1	0x3102 sub 0x04	INTEGER32	R/W
							0x0134 – 0x0135		
pQSOPTC	E38 – Quick Stop Option Code	Range							
		0					0x3102 sub 0x13	INTEGER8	R/W
		2	2 – Switch On Disabled			1			
		6	6 – Stay in Quick Stop				0x0152		
		8							
pTHRVEL	E18 - Velocity threshold	100	65535	10000	ie/s	1	0x3102 sub 0x09 (16 lsb)	INTEGER32	R/W
							0x013E		
pTIMEVEL	E20 - Velocity threshold time	0	65535	0	ms	1	0x3102 sub 0x0A (16 lsb)	INTEGER32	R/W
							0x0140		
pWINVEL	E22 - Velocity window	0	65535	0	ie/s	1	0x3102 sub 0x0B (16 lsb)	INTEGER32	R/W
							0x0142		
pWTIMEVEL	E24 - Velocity window time-out	0	65535	0	ms	1	0x3102 sub 0x0C (16 lsb)	INTEGER32	R/W
							0x0144		
ACTUALPOS	d66-67 – Position actual value				ie	1	0x6064	INTEGER32	R
							0x03C2 – 0x03C3		
ACTUALVEL	d68-69 – Velocity actual value				ie/s	1	0x606C	INTEGER32	R
							0x03C4 – 0x03C5		
pVPI_LMN_MIN	E54-55 Profile Vel.PI Limit Min value of output	- 2147483 648	2147483 647	- 21474 83647	ie/s	1	0x3102 sub 0x1B	INTEGER32	R/W
							0x0162 – 0x0163		
pVPI_LMN_MAX	E56-57 Profile Vel.PI Limit Max value of output	- 2147483 648	2147483 647	21474 83647	ie/s	1	0x3102 sub 0x1C	INTEGER32	R/W
							0x0164 – 0x0165		
pVPI_KP	E58 KpV Profile Vel.PI proportional gain	-400.0	400.0	6.0		10	0x3102 sub 0x1D	INTEGER32	R/W

Name	Description	Min	Max	Default	UM	Scale	index	Type	Access
							(16 lsb) 0x0166		
pVPI_TI	E59 TiV Profile Vel.PI lead time constant	0.1	3000.0	30.0	ms	10	0x3102 sub 0x1D (16 msb) 0x0167	INTEGE R32	R/W
pVPI_TF	E60 TfV Profile Vel.PI (filter) time constant	0.0	25.0	0.4	ms	10	0x3102 sub 0x1E (16 lsb) 0x0168	INTEGE R32	R/W
ACT_COM_P_PID	d80 - Actual P component of Profile Vel. PI				%	163.84	0x200F sub 0x50 0x03D0	UNSIGN ED16	R
ACT_COM_I_PID	d81 - Actual I component of Profile Vel. PI				%	163.84	0x200F sub 0x51 0x03D1	UNSIGN ED16	R
ACT_ERR_PID	d82 - Actual Error SP-PV of Profile Vel. PI				%	163.84	0x200F sub 0x52 0x03D2	UNSIGN ED16	R
ACT_OUT_PID	d83 - Actual Output of Profile Vel. PI				%	163.84	0x200F sub 0x53 0x03D3	UNSIGN ED16	R
PrfPP_Pos_SelAI_Start HoldCam_PV	E496 - Profile Pos. AI Selection Start Hoding Cam Profile / PV for PVPI mode					1	0x300C sub 0x06 0x218C	INTEGE R8	R/W
PrfVPI_PosChgSpPI_0	E868 - 869 - 0 - Profile PI Control Speed- Pos. Change Setpoint	- 2147483 648	2147483 647	0	ie	1	0x3020 sub 0x00 0x2300 - 0x2301	INTEGE R32	R/W
PrfVPI_PosChgSpPI_1	E870 - 871 - 1 - Profile PI Control Speed- Pos. Change Setpoint	- 2147483 648	2147483 647	0	ie	1	0x3020 sub 0x01 0x2302 - 0x2303	INTEGE R32	R/W
PrfVPI_PosChgSpPI_2	E872 - 873 - 2 - Profile PI Control Speed- Pos. Change Setpoint	- 2147483 648	2147483 647	0	ie	1	0x3020 sub 0x02 0x2304 - 0x2305	INTEGE R32	R/W
PrfVPI_PosChgSpPI_3	E874 - 875 - 3 - Profile PI Control Speed- Pos. Change Setpoint	- 2147483 648	2147483 647	0	ie	1	0x3020 sub 0x03 0x2306 - 0x2307	INTEGE R32	R/W
PrfVPI_PosChgSpPI_4	E876 - 877 - 4 - Profile PI Control Speed- Pos. Change Setpoint	- 2147483 648	2147483 647	0	ie	1	0x3020 sub 0x04 0x2308 - 0x2309	INTEGE R32	R/W
PrfVPI_PosChgSpPI_5	E878 - 879 - 5 - Profile PI Control Speed- Pos. Change Setpoint	- 2147483 648	2147483 647	0	ie	1	0x3020 sub 0x05 0x230A - 0x230B	INTEGE R32	R/W
PrfVPI_PosChgSpPI_6	E880 - 881 - 6 - Profile PI Control Speed- Pos. Change Setpoint	- 2147483 648	2147483 647	0	ie	1	0x3020 sub 0x06 0x230C - 0x230D	INTEGE R32	R/W
PrfVPI_PosChgSpPI_7	E882 - 883 - 7 - Profile PI Control Speed- Pos. Change Setpoint	- 2147483 648	2147483 647	0	ie	1	0x3020 sub 0x07 0x230E - 0x230F	INTEGE R32	R/W
PrfVPI_PosChgSpPI_8	E884 - 885 - 8 - Profile PI Control Speed- Pos. Change Setpoint	- 2147483 648	2147483 647	0	ie	1	0x3020 sub 0x08 0x2310 - 0x2311	INTEGE R32	R/W

Name	Description	Min	Max	Default	UM	Scale	index	Type	Access
PrfVPI_PosChgSpPI_9	E886 - 887 - 9 - Profile PI Control Speed- Pos. Change Setpoint	-2147483648	2147483647	0.00	ie	1	0x3020 sub 0x09	INTEGER32	R/W
							0x2312 - 0x2313		
PrfVPI_SpCtrlPI_0	E888 - 0 - Profile PI Control Speed- Setpoint	-200.00	200.00	0.00	%	100	0x3021 sub 0x00	UNSIGNED 16	R/W
							0x2314		
PrfVPI_SpCtrlPI_1	E889 - 1 - Profile PI Control Speed- Setpoint	-200.00	200.00	0.00	%	100	0x3021 sub 0x01	UNSIGNED 16	R/W
							0x2315		
PrfVPI_SpCtrlPI_2	E890 - 2 - Profile PI Control Speed- Setpoint	-200.00	200.00	0.00	%	100	0x3021 sub 0x02	UNSIGNED 16	R/W
							0x2316		
PrfVPI_SpCtrlPI_3	E891 - 3 - Profile PI Control Speed- Setpoint	-200.00	200.00	0.00	%	100	0x3021 sub 0x03	UNSIGNED 16	R/W
							0x2317		
PrfVPI_SpCtrlPI_4	E892 - 4 - Profile PI Control Speed- Setpoint	-200.00	200.00	0.00	%	100	0x3021 sub 0x04	UNSIGNED 16	R/W
							0x2318		
PrfVPI_SpCtrlPI_5	E893 - 5 - Profile PI Control Speed- Setpoint	-200.00	200.00	0.00	%	100	0x3021 sub 0x05	UNSIGNED 16	R/W
							0x2319		
PrfVPI_SpCtrlPI_6	E894 - 6 - Profile PI Control Speed- Setpoint	-200.00	200.00	0.00	%	100	0x3021 sub 0x06	UNSIGNED 16	R/W
							0x231A		
PrfVPI_SpCtrlPI_7	E895 - 7 - Profile PI Control Speed- Setpoint	-200.00	200.00	0.00	%	100	0x3021 sub 0x07	UNSIGNED 16	R/W
							0x231B		
PrfVPI_SpCtrlPI_8	E896 - 8 - Profile PI Control Speed- Setpoint	-200.00	200.00	0.00	%	100	0x3021 sub 0x08	UNSIGNED 16	R/W
							0x231C		
PrfVPI_SpCtrlPI_9	E897 - 9 - Profile PI Control Speed- Setpoint	-200.00	200.00	0.00	%	100	0x3021 sub 0x09	UNSIGNED 16	R/W
							0x231D		
PrfVPI_NrPrfCtrlPI	E898 - Nr of Profile PI Control Speed	0	9	0			0x3022 sub 0x00	INTEGER 8	R/W
							0x231E		
MAX_SPEED_IE	d72-73 – Speed Max [ie] (P65 – MOT_MAX_SPEED)						0x200F sub 0x48	INTEGER32	R
							0x03C8 – 0x03C9		

Tab. 27- Profile Velocity PI control mode

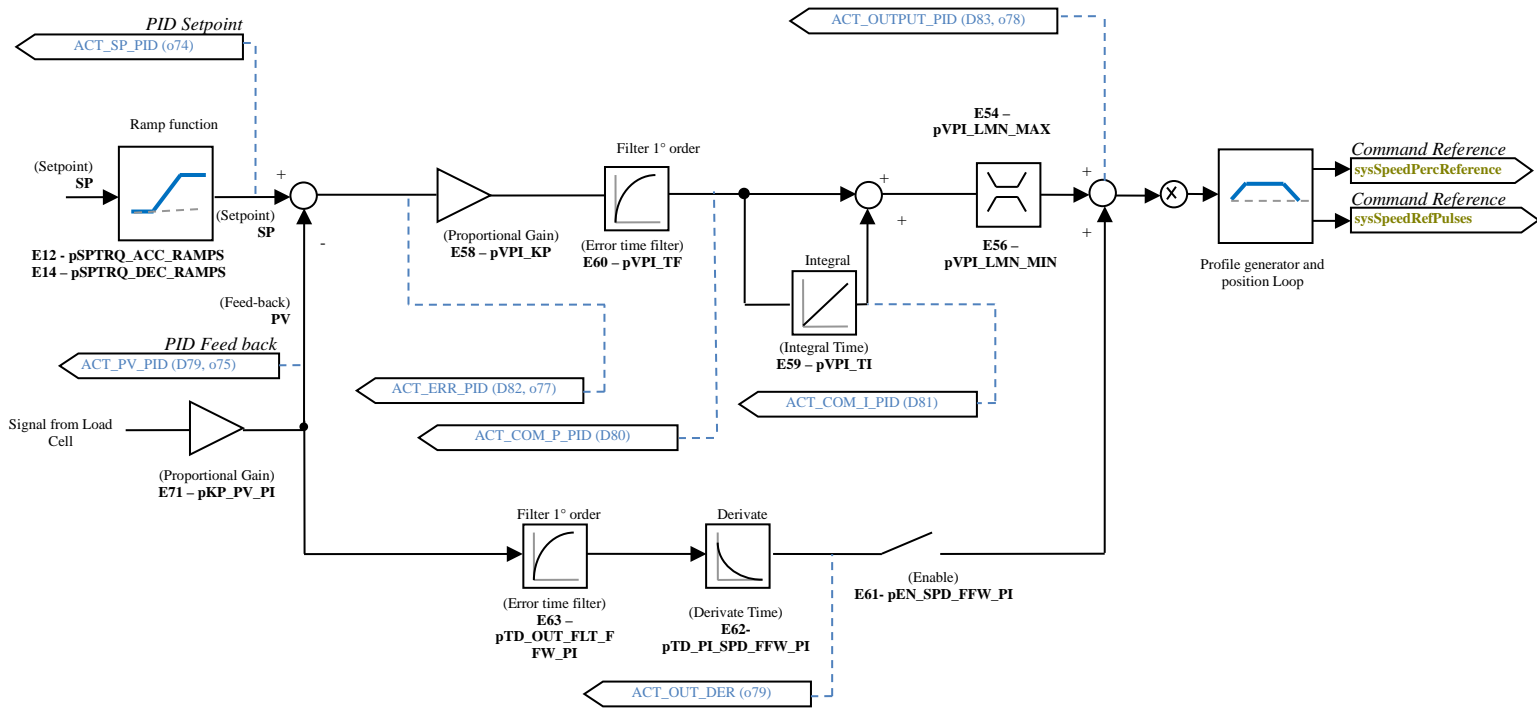

Fig. 25- Profile PI Control Mode Scheme

A torque-step set point is applied. The changing of set-points depends on the actual position. The set point can be ramp with **E12 - pSPTRQ\_ACC\_RAMPS** and **E14 - pSPTRQ\_DEC\_RAMPS**. Feedback come from load cell like torque closed loop.

User can act on this second PI ( **E58 - pVPI\_KP**, **E59 - pVPI\_TI**, **E60 - pVPI\_TF**). The output of PI is limited with **E54 - pVPI\_LMN\_MAX** and **E56- pVPI\_LMN\_MIN**.

Eventually a Speed Feed-Forward depending on the Feed-back can be enabled (filter with **E63 - pTD\_OUT\_FLT\_FFW\_PI**, derivate with **E62 - pTD\_PL\_SPD\_FFW\_PI**, enabling with **E61- pEN\_SPD\_FFW\_PI**).

PI-Output modulates a Profile generator with speed reference equal to the maximum speed (**MAX\_SPEED\_IE**) acceleration and deceleration equal to **E04 - 05 - pPROFACC** and **E06 - 07 - pPROFDEC**.

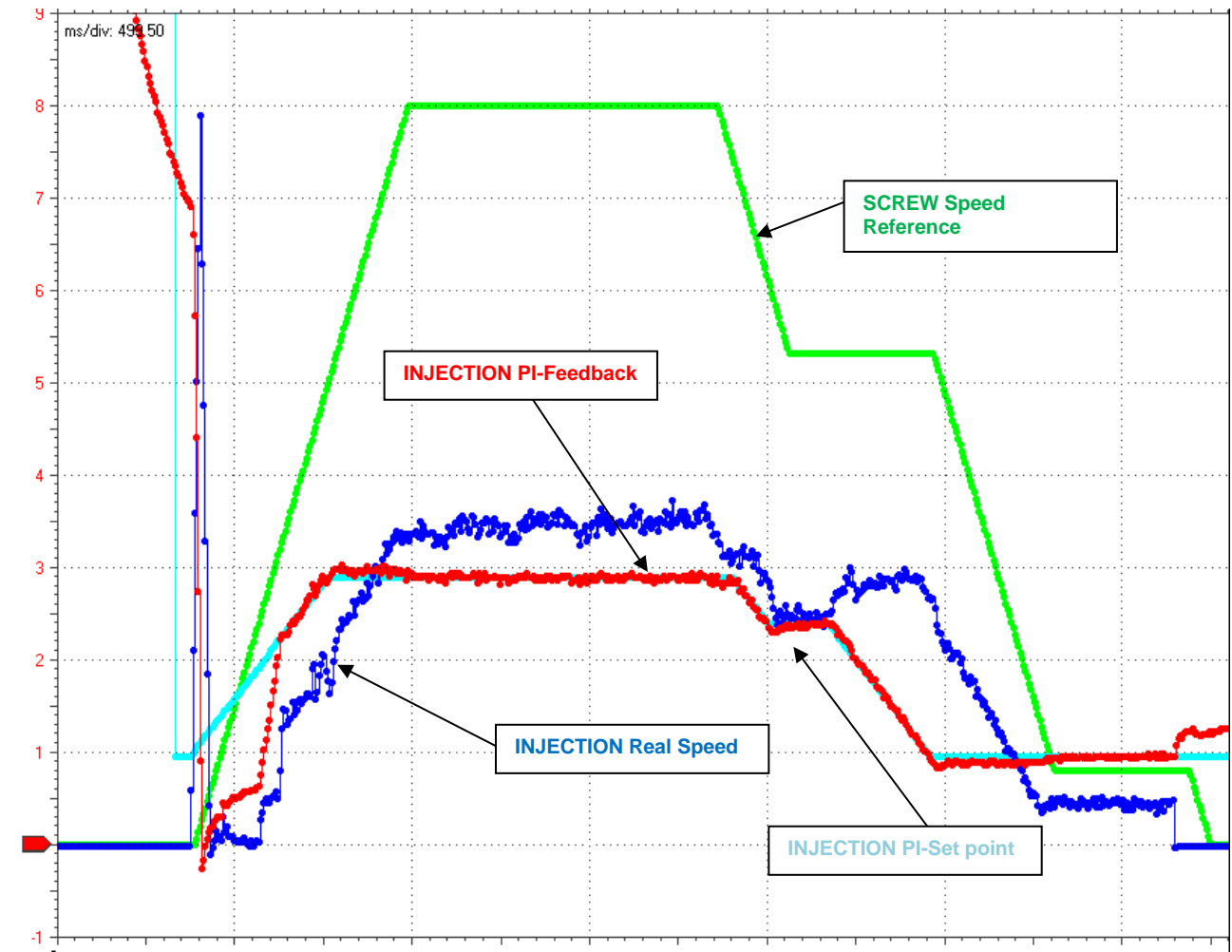
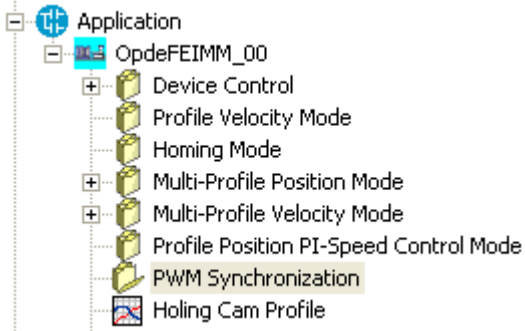

Fig. 26- Back-pressure example

Fig. 26 shows the dosing-phase for Injection and Screw axes where a Back-pressure is present. Injection Axes works in **Profile PI-Control Mode**, the PI works modulating the Profile Generator references (Fig. 27). Injection Axes send the position to Screw Axes by second line CAN2. Screw drive works in **Multi Profile Velocity**: the change of speeds depends on the position received from CAN 2.

The graphs shows also the ramps on Pressure Set Point.

## 2.9 PWM SYNCHRONIZATION



Name	Description	Min	Max	Default	UM	Scale	index	Type	Access
EN_PWM_SYNC	E85 – Enable PWM - Synchronization	Range		0		1	CAN: 0x3102 sub 0x2A (16 msb)	INTEGER3 2	R/W
		0	0 - No						
		1	1 - Master						
		2	2 - Slave						
PWM_SYNC_PHASE	E86 – PWM Synchronization phase	-175	175	0	°	1	0x3102 sub 0x2B (16 lsb)	INTEGER3 2	R/W
							0x0182		
PWM_SYNC_DELAY	D77 – PWM SYNC Delay	-400.0	400.0	0.0	us	1	0x2003 sub 0x4d	INTEGER3 2	R/W
							0x03cd		

**Tab. 28- PWM Synchronization**

With this function it's possible to synchronize two or more OPDE at PWM level.  
Parameter **E85 – EN\_PWM\_SYNC** is used to select the drive function:

- 1 Master= Every PWM period the third digital output (O3) is configured like PWM synchronization output.
- 2 Slave= Eighth physical input (I08) is used to synchronize the drive.

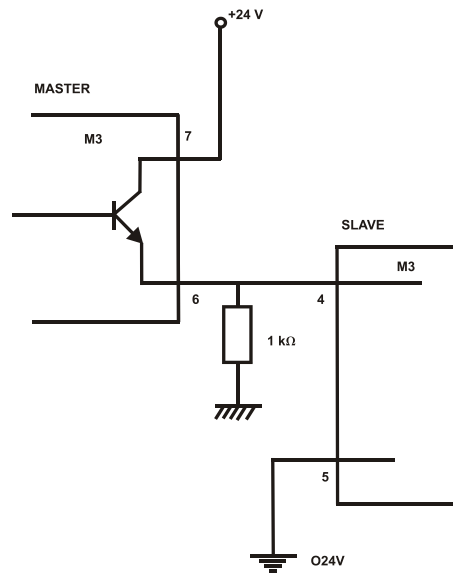

**Fig. 27- PWM Synchronization**

In the slave there is a tracking loop with gain  $K_p$  (P11) e  $T_a$  (P12). It's possible to set also the phase between master and slave with parameter **E86 – PWM Synchronization plphase**.

Note1: Master and slave have to be set with the same PWM frequency (P101)

Note2: If the PWM frequency is great than 5kHz is necessary to use a pull-down 1kΩ resistance 1W.



## 2.10 ALARMS

Alarms			Description	Correction
HEX	DEC			
A.4.0.H	A4.0	Life guarding Error	Master's timeout	Check the correct setting of the master or check the CAN cable or check the CAN setting of the drive.
A.4.1.H	A4.1	CAN 2 / SPI communication lost	CAN 2 /SPI communication lost (not data received for value in <b>E46 - THR_ALARM_COM</b> )	Check the CAN2 /SPI connection cable or check the parameter <b>E46</b>
A.4.2.H	A4.2	Tracking error too big	Tracking error too big (greater than threshold pFOLLERR E16-E17	Check the speed and position control. Verify if the drive is in torque limit and if the feed-back position is read correctly. Eventually increase the threshold ( <b>E16 – E17</b> ).

Tab. 29- Alarms table

## 2.11 DIGITAL INPUT AND OUTPUT

Digitals Inputs	
Name	Descriptions
I00	Run command
I02	External enable
I04	Profile Start Holding Cam
I05	Operative Mode Bit0
I06	Operative Mode Bit1
I07	Operative Mode Bit2
I08	Reset alarms
I10	New SetPoint
I11	Profile Positive Start Enable
I12	Profile Negative Start Enable
I20	Enable Operation
I21	Halt
I22	Quick Stop
I23	Motor thermo-switch
I28	Positive Limit Switch
I29	Negative Limit Switch
I31	PWM Synchronization Input

Tab. 30- Digital Input

Digitals Inputs	
Name	Descriptions
O32	Target Reached
O33	Set Point Acknowledge
O34	Following Error
O35	Homing Attained
O36	Op Mode Reply Bit0
O37	Op Mode Reply Bit1
O38	Op Mode Reply Bit2
O39	Operation Enabled

**Tab. 31- Application Digital Output**

OSC Variables	
Name	Descriptions
o69 – Position reference received (LSW)	Position reference less significant word
o70 – Position reference received (MSW)	Position reference more significant word
o71 – Actual Position (LSW)	Actual position less significant word
o72 – Actual Position (MSW)	Actual position more significant word
o73 – Actual position error	Actual position error
o74 – Actual Set point PI	PI closed loop (Multi Profile Position Mode) or PI velocity (Profile Position PI-Control Mode) Set point
o75 –Feedback PI	PI closed loop (Multi Profile Position Mode) or PI velocity (Profile Position PI-Control Mode) Feedback
o76 – Start holding cam profile flag	Holding Cam Profile – trigger flag
o77 – Actual PI Error	PI closed loop (Multi Profile Position Mode) or PI velocity (Profile Position PI-Control Mode) error
o78 – Actual PI Output	PI closed loop (Multi Profile Position Mode) or PI velocity (Profile Position PI-Control Mode) output
o79 – Actual Derivate Speed FFW	PI closed loop (Multi Profile Position Mode) or PI velocity (Profile Position PI-Control Mode) speed FFW

**Tab. 32- Osc variables**

OSC Application variables are refreshed every **E96 – pCYCLICPERIOD** Time (default time = 1ms).

---

### 3. APPLICATION REVISION HISTORY

---

**Rev. 71.00.74** (24/08/2015), Minimum core target: Opendrive Brushless 22.10/ Async 12.10

**Issues fixed**

--	--

**New Functionality**

71.00.74	Realized the Step Linear pressure set point reference. Adjust internal variables.
----------	---





---

**ECS**  
**TDE MACNO**

---

Via dell'Oreficeria, 41  
36100 Vicenza - Italy  
Tel +39 0444 343555  
Fax +39 0444 343509  
[www.bdfdigital.com](http://www.bdfdigital.com)