

PROGRAMMING KEY: Operating instructions

Transferring parameters from the key to the inverter:

- Remove the key connector cover and insert the key.
 - From the keyboard select parameter **C - 040**, select do then press **E**.
- The "done" message is displayed for 2 seconds to confirm that the operation has terminated successfully.

List of main parameters (see the manual for the complete list) :

D - DISPLAY menu Parameter display menu.

Code	Description	(unit of measure)
d-000	Output frequency	(0.1 Hz)
d-001	Reference frequency	(0.1 Hz)
d-002	Output current (rms)	(0.1 A)
d-003	Output voltage (rms)	(1 V)

S - START-UP menu Basic drive start-up menu.

PARAMETER	Description
S-000	Mains voltage (V)
S-001	Mains frequency (Hz)
S-100	Maximum output voltage (V)
S-101	Base frequency (Hz)
S-150	Nominal motor current
S-151	Pairs of motor poles
S-152	Plated motor cosφ value
S-153	Motor stator resistance (ohm)
S-200	START & STOP command source (1= terminals)
S-201	Maximum analog reference frequency
S-202	Reference channel source (1=AN IN1 +/-10V) (2=AN IN2 +/-10V)
S-203	Digital reference frequency
S-300	MOT-1 ramp-up time
S-301	MOT-1 ramp-down time
S-400	Manual boost
S-401	Automatic boost on/off (1=on)
S-450	Slip compensation
S-451	Compensation time constant
S-900	Stator resistance measure command
S-901	Parameter save command

I - INTERFACE menu Drive digital/analog input/output settings menu.

PARAMETER	Description
I-000 a I-007	Configure inputs IN1 to IN8
I-100 a I-103	Configure outputs OUT 1 - OUT 2 - RLA - RLB
I-200	Configure input AN1 terminal 23 (default = 0 +/-10V)
I-210	Configure input AN2 terminal 11-12 (default = 0 +/-10V)
I-300	Configure analog output 1 terminal 21 (default = 0 Freq. out)

F - FREQ& RAMP menu Multi-speed and ramp settings menu.

Code	Description
f-100 /f-115	Digital frequencies
f-116	Jogging frequencies

P - PARAMETER menu Drive functioning parameter settings menu.

Code	Description
P-001	1 = Reverse enabled without start command
P-002	1 = Reverse enabled

A - APPLICATION menu PID functioning settings menu.

C - COMMAND menu Control functions menu (Save parameters, Load defaults, Autocalibrate, etc.).

Code	Action performed
C-000	Parameter save
C-001	Load previously stored parameters
C-002	Load default parameters
C-020	Reset alarm memory
C-040	Load and save parameters from external programming key [from key to Inv.]
C-041	Save inverter parameters in external programming key [from Inv. to key]
C-100	Measure motor phase resistance and initialise parameter S-153

Configuring the programmable **digital inputs** (IN1..IN8) with: **I-000 ... I-007**.

Value	Name	Action performed
0	None	Not used
1	Run	RUN (START) command
2	Reverse	REVERSE command
3	EF NO	External fault with NO contacts
4	EF NC	External fault with NC contacts
5	Al res	Alarm reset command
7	Freq.Sel 1	Freq. selector 1
8	Freq. Sel2	Freq. selector 2

Digital (OUT1, OUT2) I-100, I-101; relay outputs (RLA, RLB) I-102, I-103

Value	Event signalled by digital output (output on)
0	Inverter ready status
1	Inverter alarm status
2	Inverter not in alarm status(negative logic)
3	Motor running
4	Motor not running
5	Anti-clockwise rotation (output off otherwise)
6	Inverter at full speed (end of ramp-up)
7	Ramping up or down.
12	Generic drive limit signal
29	Output frequency = programmed frequency P-440 & P-441
30	Output frequency ≠ programmed frequency P-440 & P-441
31	Output frequency > programmed frequency P-440 & P-441
32	Output frequency < programmed frequency P-440 & P-441

Open collector outputs **OUT1** and **OUT2** (terminals **19** and **20**) are configured by parameters **I-100** for **OUT1** and **I-101** for **OUT2**.

Relay output RLA (terminals A1, A2, A3) is programmed with I-102.

Alarms

EVENT SIGNALLED	DISPLAY	EVENT SIGNALLED	DISPLAY
External	EF	Resistance overload	OLr
Overcurrent	OC	Overtorque	Ot
Overvoltage	OU	Missing input phase	PHI
Undervoltage	UU	Not used	-
Overtemperature	OH	EEPROM error	Err
Inverter overload	OLI	Configuration error	P.Err
Motor overload	OLN	Program error	C.Err

SERIES DSV DIGITAL INVERTER

SIZE T1 - T2

Introduction

The **Serie V** inverters allow an efficient and flexible control of motor speed. In this way, the asynchronous motor can be used in a wider range of applications. The functioning interface is made of a panel consisting of six keys, one display with five 7-segment digits and seven leds.

The display and the keys allow you to change all the inverter parameters so as to make it suitable to all applications.

The drive display allows the monitoring of controlled variables as frequency, current, output voltage, cos phi, power and the storage of the last 4th alarms attempted.



Warning!



Electrical equipment can be a **source of hazards**. It is essential to fully understand how to use this equipment and all relevant safety devices before attempting to operate it.

The equipment must only be used by qualified technical personnel who are fully aware of how to install and operate it in compliance with all relevant safety standards, and who are perfectly able to understand all the associated hazard warnings. The capacitors installed inside this equipment operate at extremely high voltages. **After switching off, wait for at least 5 minutes before performing any work on the equipment.** Even when the motor is switched off, dangerous voltages can be present at the power terminals **L1, L2, L3, -, R, +, U, V, W**.

The machine can re-start automatically after a power failure under certain programming conditions.

There are no user serviceable parts inside the equipment. Only the front panel must be removed for installation.

Technical specifications

	Power supply voltage	Inverter power	Nominal output current	Phase current @230V	Phase current @400V	Motor Power @400V	Size
	Vac	kVA	A	A	A	kW	
DSV-030	230V-15% 460V+10% 50-60Hz 3-phase	5,4	7,5	8,9	10,0	3,0	T1
DSV-040		6,5	9,0	10,7	12,0	4,0	T1
DSV-055		9,1	12,5	14,7	16,5	5,5	T1
DSV-075		12,3	17	20,0	22,5	7,5	T1
DSV-110		18,1	25,0	28,9	32,5	11,0	T2
DSV-150		23,9	33,0	38,3	43,0	15,0	T2
DSV-185	27,5	38,0	44,1	49,5	18,5	T2	



This document is a quick guide to the installation and operation of the inverter. For safe, advanced use, refer to the complete manual which is available on request.

WIRING DIAGRAMS

Power terminals

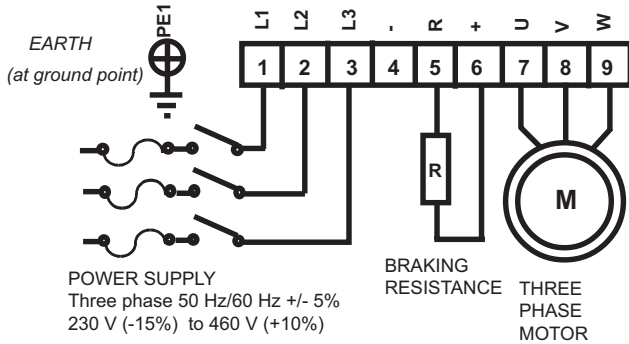

POWER CONNECTIONS

TERMINALS	N.	FUNCTION
PE1		GROUND POINT EARTH
L1	1	THREE PHASE
L2	2	MAINS POWER SUPPLY
L3	3	
-	4	DC stage negative
R	5	BRAKING RESISTANCE
+	6	DC stage positive
U	7	THREE PHASE OUTPUT
V	8	(TO MOTOR)
W	9	

Control terminals

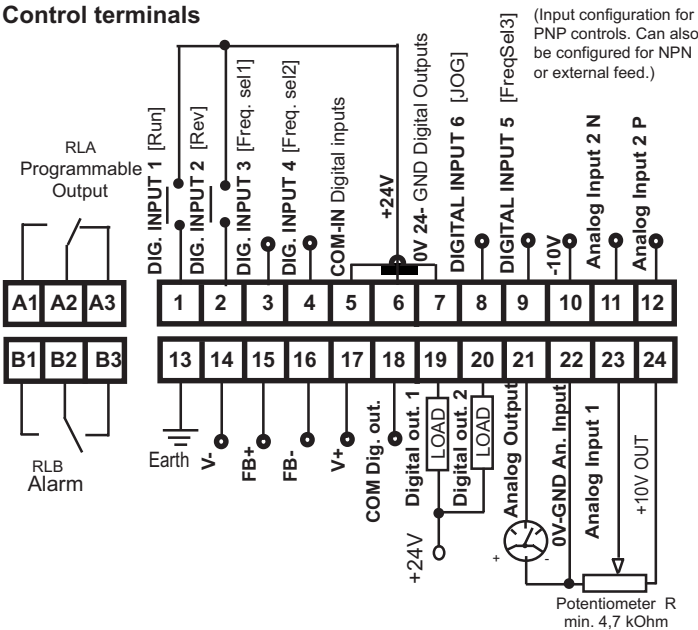

CONTROL CONNECTIONS

Strip1	Name	Function	Max
A1	Digital Output RLA-NO	Programmable relay digital output [I102=3]Motor running	230VAC0,2A
A2	Digital Output RLA-COM		125VAC0,3A(UL rating) 110VDC0,3A(UL rating)
A3	Digital Output RLA-NC		30VDC1A(UL rating)
B1	Digital Output RLB-NO	Relay digital output [I103=1]Alarm state	230VAC0,2A
B2	Digital Output RLB-COM		125VAC0,3A(UL rating) 110VDC0,3A(UL rating)
B3	Digital Output RLB-NC		30VDC1A(UL rating)
1	Digital Input1	Programmable digital input [I000=1] Run	6mA@+24V
2	Digital Input2	Programmable digital input [I001= 2]Reverse	6mA@+24V
3	Digital Input3	Programmable digital input [I002=7]Freqsel1	6mA@+24V
4	Digital Input4	Programmable digital input [I003=8] Freqsel2	6mA@+24V
5	COM-IN Digital Inputs	Digital inputs power	-
6	+24V OUT	+24Vpotential	+24V/300mA
7	0V24-GND Dig. Inputs	0 V 24 reference for digital inputs	-
8	Digital Input 6/B+ Enc.	Programmable digital input [I005] / Encoder input channelB+	HTL24V/17mA
9	Digital Input 5/A+ Enc.	Programmable digital input [I004] / Encoder input channelA+	TTL5V/9mA
10	-10V /B-Enc. Ch.	- 10Vpotential/ Encoder input channelA-	-10V/50mA
11	Analog Input 2N/A-Enc.	Programmable analog input2 [I210=0]+-10V / Enc.ChannelA-	+/-10V/0.5mA
12	Analog Input 2P	Programmable analog input2 [I210=0]+-10V/ Enc.ChannelA-	+/-10V/0.5mA
Strip2	Name	Function	Max
13	GROUND REF	Ground (earth) reference for cable shielding	-
14	V-	External positive supply	+11V....30V
15	FB+	Bus line (dominant high)	-
16	FB-	Bus line (dominant low)	-
17	V+	Ground / 0V / V-	0V
18	COM Digital outputs	Common potential for digital outputs (open collector)	-
19	Digital Output1	Programmable open collector digital output [I100=0]Drive ready	+50V/50mA
20	Digital Output2	Programmable open collector digital output [I101=6]Steady state	+/-10V/5mA
21	Analog Output1	Programmable analog output [I300=0]Freq.outabs	+/-10V/5mA
22	0V-GND Analog input	0V potential for analog inputs/outputs	-
23	Analog Input1	Programmable analog input1 [I200 =0]+/-10V	+/-10V/0.5mA
24	+10VOUT	+10V potential	+10V/50mA

JUMPERS AND CONNECTORS

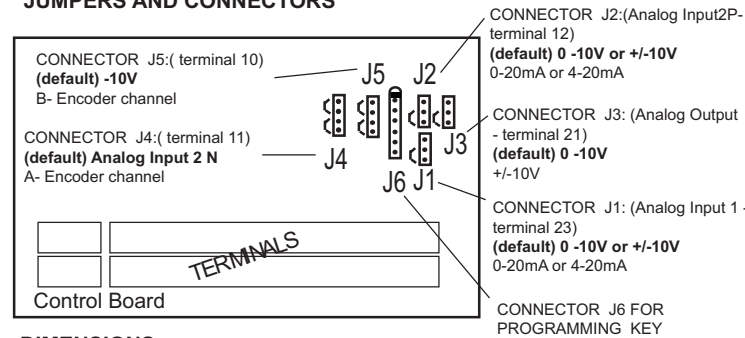

DIMENSIONS

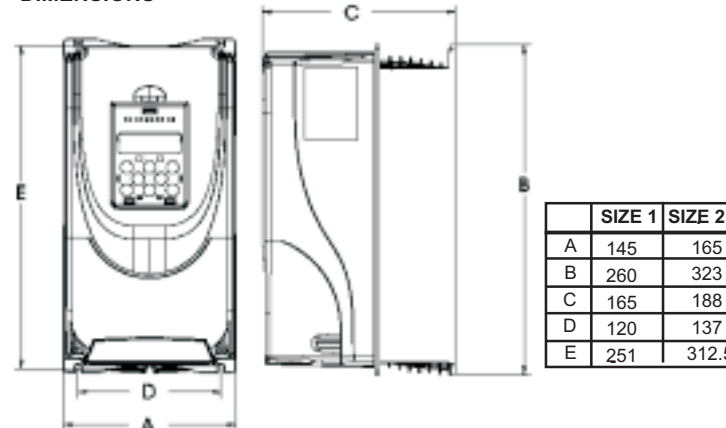

Starting

- 1- Connect a potentiometer (minimum resistance 4.7 kOhm) to provide a speed reference (terminals 22, 23, 24).
- 2- Power down the digital inputs (terminal 5) to 0V 24-GND digital outputs (terminal 7).
- 3- Connect two contacts for the start and reverse commands (terminals 1, 2, and 6).
- 4 - Close the start contacts to start the motor. The motor starts and follows the programmed ramp up to the preset frequency (default S-300= S301=5 seconds).

Stopping

To stop the motor:

- 1 - Deactivate the start command to stop the motor with the default ramp (S301= 5 seconds from maximum frequency to 0 Hz).
- 2- Alternatively, set the speed reference potentiometer to zero to control motor slowing manually.

Warning! If you stop the motor in this way, the motor remains live even when stopped.

Modifying control parameters

Let us assume that we have switched the inverter on and that we need to change the motor's maximum frequency from 50 Hz (the factory default) to 60 Hz.

The display shows 00 when switched on. Press **M** repeatedly to display the **S** menu (S- 000). Use the **↑**, **↓** keys to select code 201 (S-201) and press **E**. The S-201 (maximum frequency) parameter value appears. If the PRG LED is lit and steady, the parameter can be modified. Press **↑** until the display shows60.0 . Then press **E** to confirm and enter the new value. See point 14 in the table below to store parameters permanently.

If the motor fails to start

If the motor fails to start when you give the start command, first check that the connections have been made correctly, then check that the default inverter parameters actually suit the characteristics of the motor installed.

START-UP

Setting sequence	Description
● Go to the S - Startup menu	Press "M" to display the Startup menu.
● Inverter mains voltage	Set the inverter mains voltage in parameter S.000 :230V, 400V and 460V for FLASH.
● Inverter mains frequency	Set the inverter mains frequency in parameter S.001 : 50Hz or 60Hz.
● Maximum inverter output voltage	Set the maximum voltage for inverter output to the motor (plated value) in parameter S.100 .
● Nominal motor frequency	Set the nominal motor frequency (plated value) in parameter S.101 .
● Nominal motor current	Set the nominal motor current (plated value) in parameter S.150 .
● Motor pole pairs	Set the number of motor pole pairs (poles/2) in parameter S.151 .
● Motor power factor	Set the motor power factor (COSΦ)(plated value) in parameter S.152
● Command mode	Set the command mode in parameter S.200 - [1] = Terminals - commands from terminals (default)
● Maximum reference frequency	Set the inverter's maximum reference frequency (analog reference) in parameter S.201 .
● Reference source	Set the source of the inverter reference frequency in parameter S.202 : - [1] = 0-10V reference on AN IN1 terminal 30 (default) - [2] = +/-10V reference on AN IN2 terminal 27
● Inverter ramp up and down times	Set the ramp up time in parameter S.300 . Set the ramp down time in parameter S.301 .
● Motor stator resistance autocalibration	Enable motor stator resistance autocalibration in parameter S.900 : - "do" appears on the 7 segment display when enabled.
● Save parameters	Enable parameter saving in the inverter's non-volatile memory in parameter S.901 .